



JOURNEY
OF
AIR

41,6-233,3
m³/min

1471-8240
cfm

14
bar

FLANGED WATER SEPARATORS

Dalgakiran water separators are designed to remove liquid water and some particulates in compressed air at the compressor outlet. Their unique centrifugal effect separates heavier-than-air matter and the low pressure drop makes them energy-efficient.



Advantages

F WS models have 3" - 8" pipes for flow rates up to 14.000 m³/h. Line filters should be used to remove unwanted substances left in the compressed air after the extremely efficient water separators.

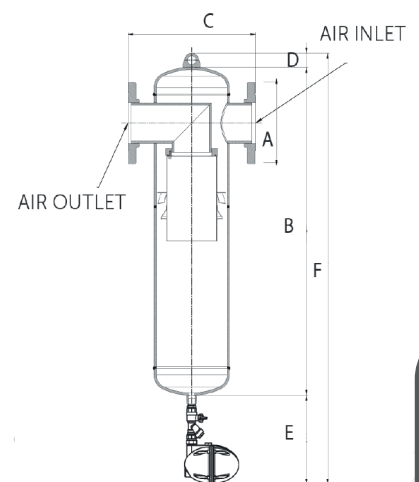

MODEL	Max. Pressure		Capacity		Connec- tion Size	Dimensions (mm)					
	bar	psi	m ³ /min	cfm		A	B	C	D	E	F
F 2500 WS	14	203	41,6	1471	DN80	200	934	450	75	280	1289
F 3200 WS	14	203	53,3	1883	DN100	220	964	450	75	280	1319
F 4300 WS	14	203	71,6	2531	DN100	220	928	530	75	280	1283
F 6500 WS	14	203	108,3	3826	DN150	285	1092	580	75	280	1447
F 8500 WS	14	203	141,6	5003	DN150	285	1091	650	75	280	1446
F 11000 WS	14	203	183,3	6474	DN200	340	1168	750	75	280	1523
F 14000 WS	14	203	233,3	8240	DN200	340	1201	800	75	280	1556