

EQUIPMENT

D/LG/KIR/N



JOURNEY OF AIR

This line represents the standard we have set at many points.

Actually, It's an endless journey, and whatever the conditions,
we will accompany you throughout this journey.

As Dalgakıran, we understand all your needs for high quality compressed air
and offer products and services that will provide maximum added value to you
and your processes with our quality standards and advanced engineering
approach with our productive and dynamic teammates.

D/ALG/KIR/N



ABOUT US

Türkiye's largest manufacturer and exporter of industrial compressors, Dalgakıran Kompresör was founded in Istanbul in 1965 by Ömer Dalgakıran in a modest workshop measuring 25 m². Dalgakıran Kompresör has grown rapidly since the day it was founded through the investments it made and today owns the compressor production plant with more than a total closed area covering 70.000 m².

As one of Türkiye's top 500 exporters, it reliably exports compressors to more than 130 countries and continues to work, invest, and grow for the improvement of industry and economy.



Since
1965

A big Family
900+

Total Closed Area
70.000+ m²

Continuing to work in the globalizing market focused on customer satisfaction with more than 55 years of experience and a dynamic staff, Dalgakıran provides rapid service all over the world through its 150+ international dealerships, overseas branches, and extensive service network.

DALGAKIRAN

Global Presence
130+ Countries

In 5 Countries
23+ Locations

COMPRESSED AIR DRYERS

Dryair DK - Refrigerated Type Air Dryers.....	06
DK HPN - Refrigerated Type High Pressure Air Dryers	08
DK-DS - Digital Scroll Compressed Air Dryers.....	10
DIC - Ice Cube Static Compressed Air Dryers.....	12
DK HT - Refrigerated Type High Temperature Compressed Air Dryers	13
DRC - Refrigerated Type Cycling (Thermal Mass) Air Dryers.....	14
DMD - Modular Adsorption Compressed Air Dryers	16
DMD VP - Vacuum Purge Modular Adsorption Compressed Air Dryers	18
DA - Heatless Adsorption Compressed Air Dryers.....	20
DBP - Blower Purge Adsorption Compressed Air Dryers.....	22
DBS - Breathing Air Systems	24



DAWGIRAN
CE

SIMATIC HMI
H0701

DAWGIRAN

EMERGENCY STOP

EMERGENCY STOP



? What is a refrigerated air dryer?

They cool the compressed air passing through them and keep that air dry down to the dew point of +3°C. Inlet and outlet filters integrated into the dryer (up to the DK 210 model) reduce the particle level by 0.01 microns and the oil particle level by 0.01 mg/m³.

🔧 Key Features

- Very low pressure losses
- Design suitable for tropical climates
- R-134a Refrigerant
- Operates at 60°C inlet temperature and 50°C ambient temperature
- Compact design
- Minimum footprint
- Digital controller for energy savings
- High efficiency
- Ease of access
- Separate electrical and cooling sections

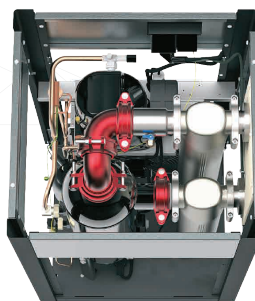

MODEL	Capacity*		Connection Size	Voltage**	Refrigerant	Maximum Working Pressure	Maximum Ambient Temperature	Maximum Inlet Temperature	Included Filter and Type	Dimensions (mm)			Weight
	m ³ /min	cfm				bar	°C	°C		Length	Width	Height	Kg
Dryair DK 10	0,35	12	G ½"	230V/1/50 Hz	R-134a	16	50	60	GKON 55 MX+MY	423	393	567	32
Dryair DK 20	0,58	20	G ½"	230V/1/50 Hz	R-134a	16	50	60	GKON 55 MX+MY	423	393	567	32
Dryair DK 30	0,83	29	G ½"	230V/1/50 Hz	R-134a	16	50	60	GKON 55 MX+MY	423	393	567	32
Dryair DK 35	1,05	37	G ½"	230V/1/50 Hz	R-134a	16	50	60	GKON 75 MX+MY	423	393	567	35
Dryair DK 40	1,45	51	G ¾"	230V/1/50 Hz	R-134a	16	50	60	GKON 155 MX+MY	473	453	832	51
Dryair DK 50	2,17	77	G ¾"	230V/1/50 Hz	R-134a	16	50	60	GKON 155 MX+MY	473	453	832	53
Dryair DK 60	2,83	100	G ¾"	230V/1/50 Hz	R-134a	16	50	60	GKON 155 MX+MY	473	453	832	55
Dryair DK 70	3,30	117	G 1 ½"	230V/1/50 Hz	R-134a	16	50	60	GKON 405 MX+MY	553	503	874	78
Dryair DK 80	4,7	166	G 1 ½"	230V/1/50 Hz	R-134a	16	50	60	GKON 405 MX+MY	553	503	874	83
Dryair DK 90	5,9	208	G 1 ½"	230V/1/50 Hz	R-134a	16	50	60	GKON 405 MX+MY	553	503	874	86
Dryair DK 100	7,8	275	G 2"	230V/1/50 Hz	R-134a	16	50	60	GKON 805 MX+MY	678	648	1157	160
Dryair DK 110	9,8	346	G 2"	230V/1/50 Hz	R-134a	16	50	60	GKON 805 MX+MY	678	648	1157	165
Dryair DK 120	13,8	487	G 2"	230V/1/50 Hz	R-134a	16	50	60	GKON 1205 MX+MY	948	728	1370	220
Dryair DK 130	18,3	646	G 2"	230V/1/50 Hz	R-134a	16	50	60	GKON 1205 MX+MY	948	728	1370	230
Dryair DK 140	21,8	770	G 3"	400V/3/50Hz	R-134a	16	50	60	GKON-HC-1805 MX+MY	948	798	1460	270
Dryair DK 150	27,1	957	G 3"	400V/3/50Hz	R-134a	16	50	60	GKON-HC-1805 MX+MY	948	798	1460	285
Dryair DK 160	36,7	1296	G 3"	400V/3/50Hz	R-134a	16	50	60	GKON-HC-2775 MX+MY	1163	778	1725	392
Dryair DK 170	43,7	1543	G 3"	400V/3/50Hz	R-134a	16	50	60	GKON-HC-2775 MX+MY	1163	778	1725	410
Dryair DK 180	52,4	1850	DN100	400V/3/50Hz	R-134a	16	50	60	GKO 5850 MX-MY	1397	847	1770	492
Dryair DK 190	61,6	2175	DN100	400V/3/50Hz	R-134a	16	50	60	GKO 5850 MX-MY	1397	847	1770	520
Dryair DK 200	80,0	2825	DN100	400V/3/50Hz	R-134a	16	50	60	GKO 5850 MX-MY	1467	1077	1930	696
Dryair DK 210	92,0	3249	DN100	400V/3/50Hz	R-134a	16	50	60	GKO 5850 MX-MY	1467	1077	1930	718
Dryair DK 220	109,7	3874	DN150	400V/3/50Hz	R-134a	16	50	60	Not Included	2188	1062	1925	900
Dryair DK 230	123,9	4375	DN150	400V/3/50Hz	R-134a	16	50	60	Not Included	2188	1062	1925	925
Dryair DK 240	141,6	5001	DN150	400V/3/50Hz	R-134a	16	50	60	Not Included	2247	1200	2044	975
Dryair DK 250	165,2	5834	DN200	400V/3/50Hz	R-134a	16	50	60	Not Included	2247	1200	2044	1100
Dryair DK 260	196,7	6946	DN200	400V/3/50Hz	R-134a	16	50	60	Not Included	2550	1550	2100	1400

- DALGAKIRAN reserves its rights to change the specifications without any prior notice.

* Capacity is given at atmospheric Pressure at 20 °C (ISO 1217) in accordance with norms ISO 7183-8573-1 and Pneurop 6611- Class 4-7 bar -35 °C inlet - 25 °C ambient.

** Consult sales representative for optional voltages

PRE FILTER (X)

Efficiency rating:
1 Micron particle removal & 0.5mg/m³ oil removal

FINE FILTER (Y)

Efficiency rating:
0.01 Micron particle removal & 0.01mg/m³ oil removal

PARTICLE FILTER (P)

Efficiency rating:
5 Micron particle removal
(removes desiccant particles after the dryer)

ACTIVATED CARBON FILTER (A)

Efficiency rating:
0.01 Micron particle removal & 0.003 mg/m³ oil removal

DRYAIR DK Dryer Sizing Example;

If a compressor delivers 20 m³/min at 6 bar, the dryer inlet temperature is 40°C and the ambient temperature is 30°C, please choose your dryer as follows;

$$\text{Dryer Capacity} = 20 / 0.94 / 0.92 / 0.98 = 23,6 \text{ m}^3/\text{min}$$

The correct dryer model for this application is Dryair DK 150.

CORRECTION FACTORS FOR DRYAIR DK AIR DRYERS:								
Inlet Temperature °C	30	35	40	45	50	60	-	-
F1	1,29	1	0,92	0,78	0,65	0,45	-	-
Ambient Temperature °C	20	25	30	35	40	50	-	-
F2	1,05	1	0,98	0,93	0,84	0,7	-	-
Pressure Bar	4	6	7	8	10	12	14	16
F3	0,80	0,94	1	1,04	1,11	1,16	1,22	1,25



What is a high-pressure compressed air dryer?

They ensure 100% contact between the air and refrigerant circuits. They offer excellent cooling by combining high efficiency with advanced performance.



Key Features

- Latest technology 3-in-1 design
- Low pressure difference
- Compact design with 3-in-1 heat exchanger
- Meets every capacity and power requirement
- Stainless steel, brazed, plated heat exchanger
- Size reduction and excellent heat transfer
- Corrosion prevention
- Safety test against leakages

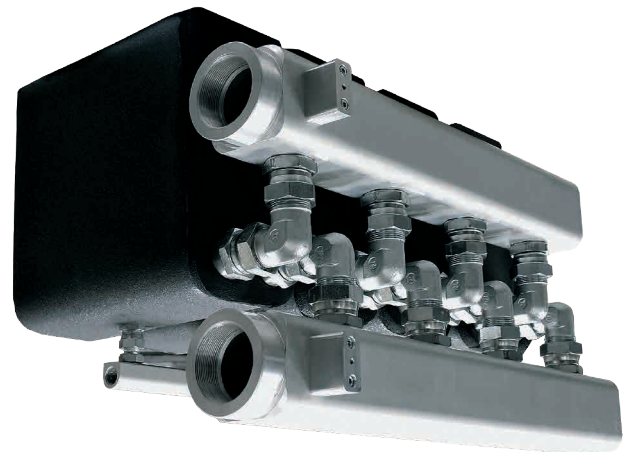

Size Reduced
by 50%



Dewpoint 3°C



Stainless Steel,
Anti-corrosion



Working Pressure
Up to 45 bar



Inlet/Outlet
Temp. Difference
<10°C

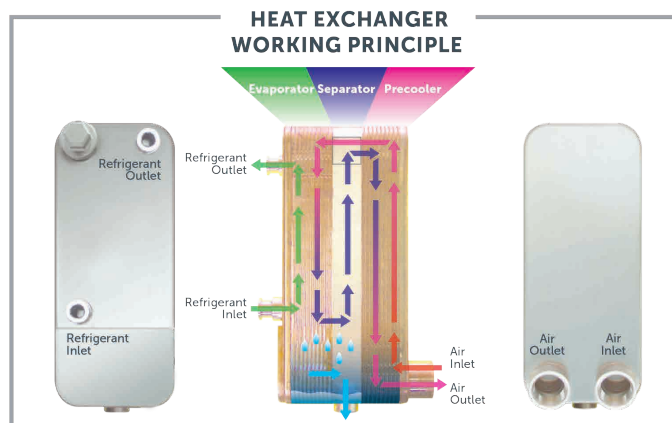

Model	Capacity*		Connection Size	Voltage	Maximum Working Pressure	Maximum Ambient Temperature	Maximum Inlet Temperature	Dimensions (mm)			Weight
	m ³ /min	cfm			bar	°C	°C	Length	Width	Height	Kg
DK 50 HPN	0,83	29	G ¾"	230V/1/50 Hz	45	45	50	454	361	553	36
DK 90 HPN	1,50	53	G ¾"	230V/1/50 Hz	45	45	50	454	361	553	38
DK 150 HPN	2,50	88	G ¾"	230V/1/50 Hz	45	45	50	453	401	623	45
DK 220 HPN	3,67	130	G ¾"	230V/1/50 Hz	45	45	50	453	401	623	45
DK 300 HPN	5,00	177	G 1 ¼"	230V/1/50 Hz	45	45	50	505	451	761	70
DK 400 HPN	6,67	236	G 1 ¼"	230V/1/50 Hz	45	45	50	505	451	761	72
DK 500 HPN	8,33	294	G 1 ¼"	230V/1/50 Hz	45	45	50	505	451	812	78
DK 575 HPN	9,58	338	G 1 ¼"	230V/1/50 Hz	45	45	50	505	451	812	80
DK 775 HPN	12,9	456	G 1 ¼"	230V/1/50 Hz	45	45	50	675	501	984	115
DK 910 HPN	15,2	537	G 1 ¼"	230V/1/50 Hz	45	45	50	675	501	984	120
DK 1000 HPN	16,7	590	G 2"	230V/1/50 Hz	45	45	50	947	727	1170	218
DK 1160 HPN	19,4	685	G 2"	230V/1/50 Hz	45	45	50	947	727	1170	220
DK 1500 HPN	25,0	883	G 2"	230V/1/50 Hz	45	45	50	947	727	1170	225
DK 1600 HPN	26,7	943	G 2"	400V/3/50Hz	45	45	50	947	797	1460	263
DK 1800 HPN	30,0	1059	G 2"	400V/3/50Hz	45	45	50	947	797	1460	265
DK 2200 HPN	36,7	1296	G 2 ½"	400V/3/50Hz	45	45	50	1162	797	1495	352
DK 2500 HPN	41,7	1473	G 2 ½"	400V/3/50Hz	45	45	50	1162	797	1495	353
DK 2700 HPN	45,0	1589	G 2 ½"	400V/3/50Hz	45	45	50	1162	797	1495	355
DK 3000 HPN	50,0	1766	G 2 ½"	400V/3/50Hz	45	45	50	1162	797	1495	422
DK 3300 HPN	55,0	1942	G 2 ½"	400V/3/50Hz	45	45	50	1162	797	1495	423
DK 3600 HPN	60,0	2119	G 2 ½"	400V/3/50Hz	45	45	50	1162	797	1495	425

- DALGAKIRAN reserves its rights to change the specifications without any prior notice.

* Nominal flow is calculated at the following conditions: Inlet Pressure: 40 bar, Inlet Temperature: 35°C Ambient Temperature 25°C for other conditions please refer to the correction factor table.

PRE FILTER (X)

Efficiency rating:
1 Micron particle removal & 0.5mg/m³ oil removal

FINE FILTER (Y)

Efficiency rating:
0.01 Micron particle removal & 0.01mg/m³ oil removal

DK HPN Dryer Sizing Example;
If a compressor delivers 20 m³/min at 35 bar, the dryer inlet temperature is 40°C and the ambient temperature is 30°C, please choose your dryer as follows;

PARTICLE FILTER (P)

Efficiency rating:
5 Micron particle removal
(removes desiccant particles after the dryer)

ACTIVATED CARBON FILTER (A)

Efficiency rating:
0.01 Micron particle removal & 0.003 mg/m³ oil removal

Dryer Capacity = 20 / 0,96 / 0,82 / 0,63 = 40,3 m³/min

The correct dryer model for this application is DK 2500 HPN.

CORRECTION FACTORS FOR DK-HPN SERIES									
Pressure (bar)	20	25	30	35	40	45	-	-	-
F1	0,84	0,91	0,93	0,96	1	1,02	-	-	-
Ambient Temperature (°C)	-	-	-	-	25	30	35	40	45
F2	-	-	-	-	1	0,93	0,87	0,82	0,79
Inlet Temperature (°C)	-	-	-	-	35	40	45	50	-
F3	-	-	-	-	1	0,85	0,72	0,63	-



The new DK-DS series uses proprietary digital evaporator technology to deliver significant energy savings over conventional cycle and variable speed designs. Using advanced technology, it operates within different inlet flow ranges, making it by far the most efficient compressor to be used in a refrigerated air dryer. DK-DS Dryers are equipped with a true loss-free condensate drainage ensuring effective condensate drainage without any loss of compressed air. Constantly communicating with the temperature probe in the evaporator, it adjusts the cooling pressure according to the temperature of the air leaving the evaporator, thus saving energy.

Basic Components

- Digital Scroll Compressor
- Electronic Expansion Valve
- Variable Speed Fan Motor
- Well-engineered Control Algorithm
- Cutting-Edge Technology Electronic Controller



MODEL	Capacity (m³/min)	Voltage (V/ph/Hz)	Ref. Gas Type	Connection	Filter Set
DK-DS 120	15,50	400V/3/50	R134a	2"	GKON 1205 MX+MY
DK-DS 130	20,00	400V/3/50	R134a	2"	GKON 1205 MX+MY
DK-DS 140	23,13	400V/3/50	R134a	3"	GKON 1805 MX+MY
DK-DS 150	30,00	400V/3/50	R134a	3"	GKON 1805 MX+MY
DK-DS 170	46,25	400V/3/50	R134a	3"	GKON-HC-2775 MX+MY
DK-DS 180	55,50	400V/3/50	R134a	DN100	GKON-HC-2775 MX+MY
DK-DS 190	65,25	400V/3/50	R134a	DN100	GKON-HC-5850 MX+MY
DK-DS 200	84,75	400V/3/50	R134a	DN100	GKON-HC-5850 MX+MY
DK-DS 210	97,50	400V/3/50	R134a	DN100	GKON-HC-5850 MX+MY
DK-DS 220	116,25	400V/3/50	R134a	DN150	GKON-HC-5850 MX+MY
DK-DS 230	131,25	400V/3/50	R134a	DN150	-
DK-DS 240	150,00	400V/3/50	R134a	DN150	-
DK-DS 250	175,00	400V/3/50	R134a	DN200	-
DK-DS 260	208,33	400V/3/50	R134a	DN200	-

What Makes DK-DS so energy efficient and cost effective?

Dryers with digital scroll technology based on the standard refrigerated type dryer can automatically switch to load or unload depending on real-time compressed air demand. This feature makes the DK-DS series much more energy-efficient than all other types of refrigerated air dryers.

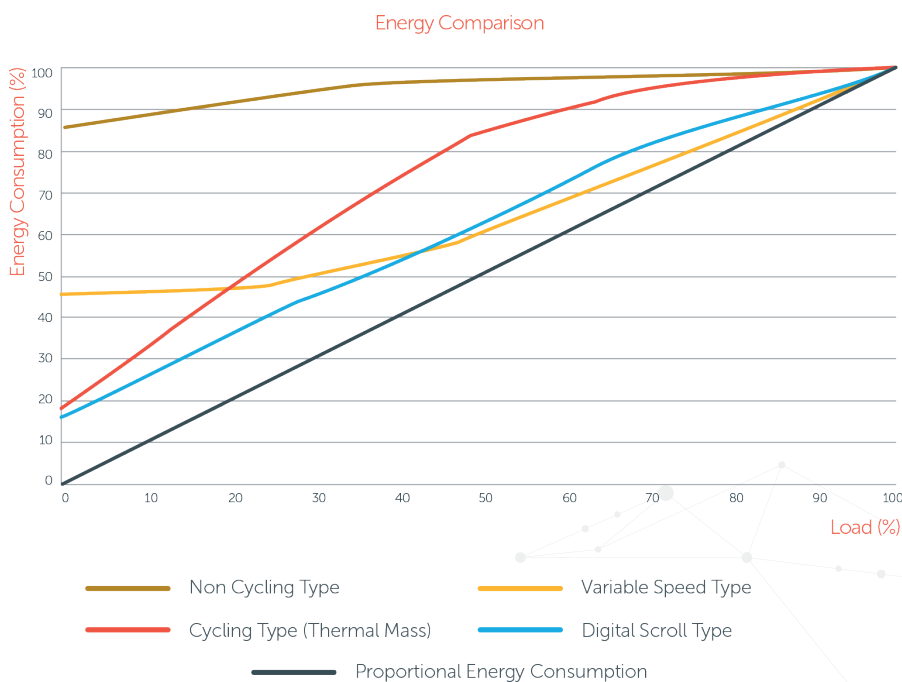



DIC Series dryers use a static condenser eliminating the need for a fan. They therefore work quietly and use little electricity. Compact and durable, DIC Series dryers have a long life span and require little servicing.

Advantages

- Simple design takes up little space and delivers years of service-free operation
- Static condenser offers superior energy savings
- Efficient refrigerant compressor with low pressure drop
- Low pressure loss
- +7°C dew point
- Wide condenser design eliminates condenser blockages
- Standard expansion valve
- 3-in-1 heat exchanger design (air/air - air/refrigerant - water separator)
- Easy-to-service auto-drain
- High-pressure switch
- No loss of compressed air (Zero Loss)
- Uses less refrigerant than equivalents, environmentally friendly.

CORRECTION FACTORS FOR DIC SERIES								
Inlet Temperature °C	30	35	40	45	50	60	-	-
F1	1,29	1	0,92	0,78	0,65	0,45	-	-
Ambient Temperature °C	20	25	30	35	40	45	50	-
F2	1,05	1	0,98	0,93	0,84	0,76	0,7	-
Pressure (Barg)	4	6	7	8	10	12	14	16
F3	0,8	0,94	1	1,04	1,11	1,16	1,22	1,25

Correction Formula: Dryer Capacity = Air Delivery Capacity of the Compressors / F1 / F2 / F3

Model	Max. Working Pressure (bar)	Capacity (m ³ /min)	Voltage	Connection Size	Refrigerant Gas	Filter Set	Pressure Drop	Dimensions (mm)			Weight (kg)
								Length	Width	Height	
DIC 50	16	0,83	230/1/50	1/2"	R-134a	GKON 55 MX+MY	140	396	366	520	21
DIC 70	16	1,16	230/1/50	1/2"	R-134a	GKON 75 MX+MY	170	396	366	520	23
DIC 100	16	1,66	230/1/50	3/4"	R-134a	GKON 75 MX+MY	200	396	366	520	25
DIC 130	16	2,16	230/1/50	3/4"	R-134a	GKON 155 MX+MY	180	396	366	758	34



High-Temperature Air Dryers are fitted with an aftercooler to lower the inlet temperature of the compressed air. This ensures effective dew-point management.



Key Features

- High operating inlet temperature
- Integrated condenser
- Independent air-cooled aftercooler
- Moisture separator
- Automatic drain
- Environmentally friendly R134a refrigerant
- Increased compressor life span
- Operate in high ambient temperatures
- Excellent insulation
- Easy to assemble and maintain

CORRECTION FACTORS FOR DRD H SERIES												
Pressure (bar)	4	5	6	7	8	8,5	10	11	12	13	14	16
F1	0,70	0,75	0,80	0,83	0,86	0,90	0,93	0,96	1	1,1	1,12	1,15
Ambient Temperature °C	24	29	35	38	40	46	49	-	-	-	-	-
F2	1,10	1,07	1,03	1,00	0,96	0,82	0,55	-	-	-	-	-
Inlet Temperature °C	32	38	65	82	93	98	104	-	-	-	-	-
F3	1,30	1,27	1,06	1,00	0,85	0,78	0,75	-	-	-	-	-

Correction Formula: Dryer Capacity = Air Delivery Capacity of the Compressors / F1 / F2 / F3

Model	Max. Pressure		Capacity		Connection Size	Voltage (V/ph/Hz)	Dimensions (mm)			Weight (kg)	Controller	Refrigerant Type
	bar	psi	m ³ /min	cfm			Length	Width	Height			
DK HT 31	16	232	0,52	18	G ½"	230/ 1 /50	445	445	955	62	DigiPro	R134a
DK HT 52	16	232	0,87	31	G ½"	230/ 1 /50	445	445	955	62	DigiPro	R134a
DK HT 75	16	232	1,25	44	G ½"	230/ 1 /50	445	445	955	63	DigiPro	R134a
DK HT 106	16	232	1,77	62	G ¾"	230/ 1 /50	445	445	955	64	DigiPro	R134a
DK HT 160	16	232	2,67	94	G ¾"	230/ 1 /50	625	510	910	88	DigiPro	R134a
DK HT 212	16	232	3,53	125	G ¾"	230/ 1 /50	625	510	910	97	DigiPro	R134a



These types of dryers consume energy dependent on air flow. The dryer's cooling system cools the water-glycol mixture down to 1°C and holds this mixture in a stainless steel container. A small pump circulates the water-glycol mixture to cool the compressed air. The cooling system's compressor turns off when the mixture reaches the required temperature resulting in considerable energy savings.

Advantages

- Energy savings with capacity control
- 3°C dew point
- Very low pressure drop
- Suitable for tropical conditions
- Environmentally friendly R134a refrigerant
- Large condenser
- Operates at 60°C inlet temperature and in 50°C ambient temperature
- Stainless steel components
- High efficiency



Model	Max. Pressure		Capacity		Connection Size	Filter Set	Voltage (V/ph/Hz)	Dimensions (mm)			Weight (kg)	Controller	Refrigerant Type
	bar	psi	m³/min	cfm				Length	Width	Height			
DRC 495	16	232	8,25	291	G 2"	GKON805 MX+MY	230 / 1 / 50	855	725	1505	178	DigiPro	R134a
DRC 623	16	232	10,4	366	G 2"	GKON1205 MX+MY	230 / 1 / 50	855	725	1505	184	DigiPro	R134a
DRC 930	16	232	15,5	547	G 2"	GKON1205 MX+MY	230 / 1 / 50	830	730	1765	242	DigiPro	R134a
DRC 1200	16	232	20,0	706	G 2"	GKON1205 MX+MY	400 / 3 / 50	830	730	1765	253	ESD-3	R134a
DRC 1388	16	232	23,1	817	G 3"	GKON-HC-1805 MX+MY	400 / 3 / 50	1150	800	1740	295	ESD-3	R134a
DRC 1800	16	232	30,0	1059	G 3"	GKON-HC-1805 MX+MY	400 / 3 / 50	1150	800	1740	310	ESD-3	R134a
DRC 2500	16	232	41,7	1471	G 3"	GKON-HC-1805 MX+MY	400 / 3 / 50	1315	880	1790	411	ESD-3	R134a
DRC 2775	16	232	46,3	1633	G 3"	GKON-HC-2275 MX+MY	400 / 3 / 50	1315	880	1790	443	ESD-3	R134a
DRC 3330	16	232	55,5	1960	DN100	GKON-HC-2275 MX+MY	400 / 3 / 50	1400	850	1840	537	ESD-3	R134a
DRC 3915	16	232	65,3	2304	DN100	-	400 / 3 / 50	1400	850	1840	557	ESD-3	R134a
DRC 5085	16	232	84,8	2993	DN100	-	400 / 3 / 50	1620	1080	1995	737	ESD-3	R134a
DRC 5850	16	232	97,5	3443	DN100	-	400 / 3 / 50	1620	1080	1995	760	ESD-3	R134a
DRC 6975	16	232	116,3	4105	DN150	-	400 / 3 / 50	2190	1065	2025	941	ESD-3	R134a
DRC 7875	16	232	131,3	4634	DN150	-	400 / 3 / 50	2190	1065	2025	963	ESD-3	R134a
DRC 9000	16	232	150	5297	DN150	-	400 / 3 / 50	2900	1200	2120	1025	ESD-3	R134a
DRC 10500	16	232	175	6179	DN200	-	400 / 3 / 50	2900	1200	2120	1162	ESD-3	R134a
DRC 12500	16	232	208,3	7356	DN200	-	400 / 3 / 50	2550	1550	2170	1480	ESD-3	R134a

Correction Formula: Dryer Capacity = Air Delivery Capacity of the Compressors / F1 / F2 / F3

CORRECTION FACTORS FOR HRC SERIES									
Pressure (bar)	4	6	7	8	10	12	14	16	
F1	0,80	0,94	1	1,04	1,11	1,16	1,22	1,25	
Ambient Temperature °C	20	25	30	35	40	50	-	-	
F2	1,05	1	0,98	0,93	0,84	0,70	-	-	
Inlet Temperature °C	30	35	40	45	50	60	-	-	
F3	1,29	1	0,92	0,78	0,65	0,45	-	-	

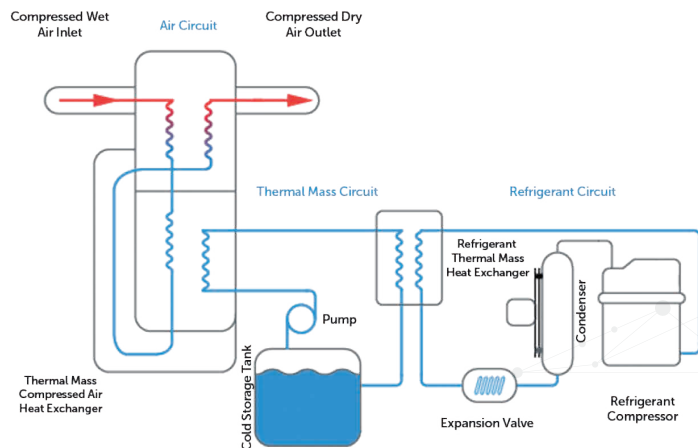



DMD model adsorption dryers use a modular design for a lightweight, compact body. Having half the size and weight of traditional twin-tower adsorption dryers, they provide users with the advantage of flexible installation. This is one of the adsorption air dryer models with the lowest pressure drop in the world with its highly engineered inlet valve and discharge manifold design.

Advantages

- Low footprint, lightweight, compact design
- Corrosion-resistant aluminium structure
- Problem-free and reliable electronic control
- Can be mounted on the floor, bench, or wall
- Suitable layout for any workplace
- Easy to install and maintain
- High efficiency and flexibility
- Energy efficient
- Dew point from -40°C to -70°C (optional)



MODEL	Max. Pressure		Capacity		Connection Size	FilterSet	Voltage (V/ph/Hz)	Dimensions (mm)			Weight kg	Controller
	bar	psi	m³/min	cfm				Length	Width	Height		
DMD 3	16	232	0,08	3	G 1/2"	GK020 MX+MY+MP	230/1/50-60	336	320	558	17	Crouzet Millenium 3
DMD 5	16	232	0,17	6	G 1/2"	GK020 MX+MY+MP	230/1/50-60	320	320	633	19	Crouzet Millenium 3
DMD 10	16	232	0,33	12	G 1/2"	GK020 MX+MY+MP	230/1/50-60	320	320	908	27	Crouzet Millenium 3
DMD 15	16	232	0,42	15	G 1/2"	GK025 MX+MY+MP	230/1/50-60	350	370	808	31	Crouzet Millenium 3
DMD 20	16	232	0,58	21	G 1/2"	GK050 MX+MY+MP	230/1/50-60	350	370	1108	42	Crouzet Millenium 3
DMD 25	16	232	0,75	26	G 1/2"	GK050 MX+MY+MP	230/1/50-60	350	370	1258	48	Crouzet Millenium 3
DMD 30	16	232	0,83	29	G 1/2"	GK050 MX+MY+MP	230/1/50-60	350	370	1508	54	Crouzet Millenium 3
DMD 40	16	232	1,17	41	G 1 1/2"	GK0100 MX+MY+MP	230/1/50-60	495	410	1250	71	Crouzet Millenium 3
DMD 50	16	232	1,42	50	G 1 1/2"	GK0100 MX+MY+MP	230/1/50-60	495	410	1400	78	Crouzet Millenium 3
DMD 60	16	232	1,67	59	G 1 1/2"	GK0100 MX+MY+MP	230/1/50-60	495	410	1750	92	Crouzet Millenium 3
DMD 75	16	232	2,17	77	G 1 1/2"	GK0150 MX+MY+MP	230/1/50-60	622	430	1300	120	Crouzet Millenium 3
DMD 100	16	232	2,83	100	G 1 1/2"	GK0200 MX+MY+MP	230/1/50-60	622	430	1450	133	Crouzet Millenium 3
DMD 120	16	232	3,33	118	G 1 1/2"	GK0200 MX+MY+MP	230/1/50-60	622	430	1750	152	Crouzet Millenium 3
DMD 180	16	232	5,00	177	G 1 1/2"	GK0300 MX+MY+MP	230/1/50-60	734	410	1499	186	Crouzet Millenium 3
DMD 240	16	232	6,67	235	G 1 1/2"	GK0500 MX+MY+MP	230/1/50-60	889	410	1497	235	Crouzet Millenium 3
DMD 340	16	232	9,6	340	2"	*	230/1/50-60	994	400	1654	*	Crouzet Millenium 3
DMD 400	16	232	11,3	400	2"	*	230/1/50-60	1335	400	1554	*	Crouzet Millenium 3
DMD 500	16	232	14,2	500	2"	*	230/1/50-60	1505	400	1654	*	Crouzet Millenium 3
DMD 590	16	232	16,7	590	2"	*	230/1/50-60	1675	400	1754	*	Crouzet Millenium 3
DMD 735	16	232	20,8	735	3"	*	230/1/50-60	1675	400	2054	*	Crouzet Millenium 3
DMD 890	16	232	25,0	890	3"	*	230/1/50-60	1845	400	2054	*	Crouzet Millenium 3
DMD 1060	16	232	30,0	1060	3"	*	230/1/50-60	2015	400	2054	*	Crouzet Millenium 3

* Please contact the sales consultant

CORRECTION FACTORS FOR DMD SERIES												
Pressure (bar)	4,5	5	6	7	8	9	10	11	12	13	14	15
F1	0,69	0,75	0,88	1	1,12	1,25	1,37	1,50	1,62	1,74	1,87	1,99
Inlet Temperature (°C)	20	25	30	35	40	45	50	-	-	-	-	-
F2	1	1	1	1	0,80	0,73	0,59	-	-	-	-	-

DMD Dryer Sizing Example;
If a compressor delivers 2,0 m³/min at 10 bar, the dryer inlet temperature is 40 °C. please choose your dryer as follows;

Dryer Capacity = 2,0 / 1,37 / 0,80 = 1,82 m³/min

The correct dryer model for this application is DMD 75.

Correction Formula: Dryer Capacity = Air Delivery Capacity of the Compressors / F1 / F2

PRE FILTER (X)
Efficiency rating:
1 Micron particle removal & 0.5mg/m³ oil removal

FINE FILTER (Y)
Efficiency rating:
0.01 Micron particle removal & 0.01mg/m³ oil removal

PARTICLE FILTER (P)
Efficiency rating:
5 Micron particle removal
(removes desiccant particles after the dryer)

ACTIVATED CARBON FILTER (A)
Efficiency rating:
0.01 Micron particle removal & 0.003 mg/m³ oil removal



The DMD-VP Series modular, vacuum purge heatless desiccant air dryers remove water vapour from the compressed air, stop corrosion, and prevent the growth of micro-organisms when supplying the clean air crucial for production. DMD-VP Series air dryers efficiently and reliably supply the system with high-quality dry air with a dew point of $-40\text{ }^{\circ}\text{C}$ or optionally a dew point of $-70\text{ }^{\circ}\text{C}$. This extends the machinery's life span, keeps maintenance costs to a minimum, and results in safe and healthy production. The new vacuum purge technology minimises air loss during regeneration and optimises production levels.



Areas of Use

- Food and Beverage
- Pharmaceutical
- Automotive
- Electronic
- All industries requiring a dew point of $-40\text{ }^{\circ}\text{C}$ or optional $-70\text{ }^{\circ}\text{C}$.

Dry Compressed Air Loss

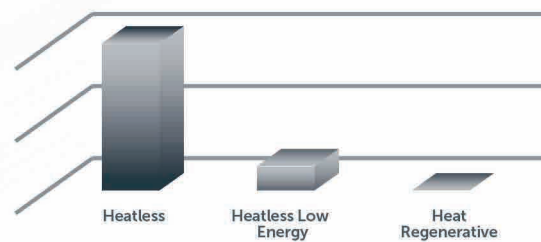

Power Consumption

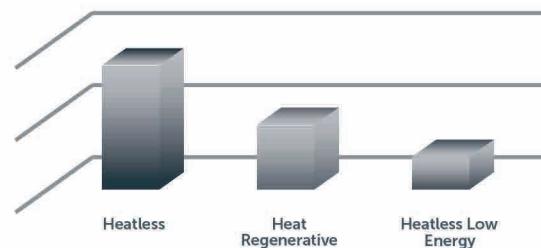

Model	Capacity	Vacuum Pump	Filter Set	Connection Size	Voltage	Max. Working Pressure
	(m ³ /min)	(kW)			(V)	(bar)
DMD-VP-60	1,66	1,1	HGON 100 MX+MY+MP	1 1/2"	400/3/50	16
DMD-VP-75	2,16	1,1	HGON 150 MX+MY+MP	1 1/2"	400/3/50	16
DMD-VP-100	2,83	1,3	HGON 225 MX+MY+MP	1 1/2"	400/3/50	16
DMD-VP-120	3,33	2,2	HGON 225 MX+MY+MP	1 1/2"	400/3/50	16
DMD-VP-180	5	2,2	HGON 400 MX+MY+MP	1 1/2"	400/3/50	16
DMD-VP-240	6,66	3	HGON 500 MX+MY+MP	1 1/2"	400/3/50	16
DMD-VP-340	9,58	4	HGON 600 MX+MY+MP	1 1/2"	400/3/50	16
DMD-VP-400	11,33	4	HGON 800 MX+MY+MP	2"	400/3/50	16
DMD-VP-500	14,16	5,5	HGON 1000 MX+MY+MP	2"	400/3/50	16
DMD-VP-590	16,66	5,5	HGON 1000 MX+MY+MP	2"	400/3/50	16
DMD-VP-740	20,83	7,5	HGON 1550 MX+MY+MP	3"	400/3/50	16

AIR LINE DESIGN

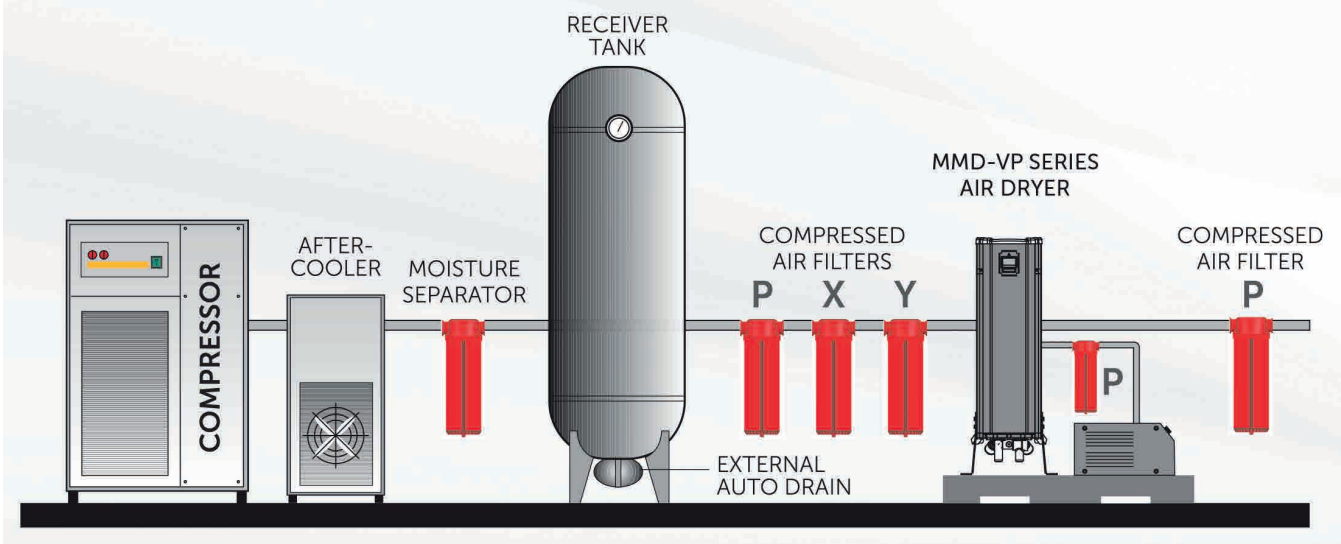



Designed to supply clean and very dry air for critical applications. They have a constant dew point of -40°C (-70°C optional).

They come with inlet and outlet line filters to keep the air flow clean and to protect the chemical mixture inside the tanks.

Advantages

- Uninterrupted and perfect operation
- -40°C (-70°C optional) pressurized dew point
- Optional dew point monitoring and control
- 16 and 40 bar working pressure options
- Constant dew point
- Easy-to-use control panel
- Touchscreen interface
- User friendly
- Different language options



MODEL	Max. Pressure		Capacity		Connection Size	Filters	Voltage	Dimensions (mm)			Weight	Controller
	bar	psi	m³/min	cfm				V/ph/Hz	Length	Width		
DA 130	10	145	2,17	77	G 1"	GK0150 MX+MY+MP	230/1/50-60	814	600	1312	160	Crouzet Millenium 3
DA 185	10	145	3,08	109	G 1"	GK0200 MX+MY+MP	230/1/50-60	806	600	1566	180	Crouzet Millenium 3
DA 250	10	145	4,17	147	G 1"	GK0250 MX+MY+MP	230/1/50-60	772	760	1580	200	Crouzet Millenium 3
DA 300	10	145	5,00	177	G 1 1/2"	GK0300 MX+MY+MP	230/1/50-60	900	690	1558	250	Crouzet Millenium 3
DA 360	10	145	6,00	212	G 1 1/2"	GK0500 MX+MY+MP	230/1/50-60	900	690	1558	250	Crouzet Millenium 3
DA 440	10	145	7,33	259	G 1 1/2"	GK0500 MX+MY+MP	230/1/50-60	900	698	1759	340	Crouzet Millenium 3
DA 575	10	145	9,58	338	G 1 1/2"	GK0600 MX+MY+MP	230/1/50-60	900	680	1991	500	Crouzet Millenium 3
DA 680	10	145	11,3	400	G 2"	GK0851 MX+MY+MP	230/1/50-60	960	680	2216	535	Crouzet Millenium 3
DA 850	10	145	14,2	500	G 2"	GK0851 MX+MY+MP	230/1/50-60	1016	857	2277	750	Crouzet Millenium 3
DA 1000	10	145	16,7	589	G 2"	GK01210 MX+MY+MP	230/1/50-60	1075	1010	2386	755	Schneider
DA 1250	10	145	20,8	736	DN80	GK01820 MX+MY+MP	230/1/50-60	1294	1100	2413	1000	Schneider
DA 1500	10	145	25,0	883	DN80	GK01820 MX+MY+MP	230/1/50-60	1300	1010	2547	1050	Schneider
DA 1800	10	145	30,0	1059	DN80	GK01820 MX+MY+MP	230/1/50-60	1513	1110	2479	1215	Schneider
DA 2200	10	145	36,7	1295	DN80	GK02220 MX+MY+MP	230/1/50-60	1460	1110	2793	1550	Schneider
DA 2700	10	145	45,0	1589	DN80	GK02700 MX+MY+MP	230/1/50-60	1533	1252	2831	1890	Schneider
DA 3200	10	145	53,3	1883	DN100	GK03200 MX+MY+MP	230/1/50-60	1653	1212	3054	2240	Schneider
DA 3600	10	145	60,0	2119	DN100	GK04300 MX+MY+MP	230/1/50-60	1653	1210	3268	2330	Schneider
DA 4400	10	145	73,3	2590	DN100	GK04300 MX+MY+MP	230/1/50-60	1905	1535	2910	3000	Schneider
DA 5000	10	145	83,3	2943	DN150	F6500 MX+MY+MP	230/1/50-60	1843	1714	3382	3180	Schneider
DA 6300	10	145	105,0	3708	DN150	F6500 MX+MY+MP	230/1/50-60	2114	1693	3328	3450	Schneider
DA 7200	10	145	120,0	4238	DN150	F8500 MX+MY+MP	230/1/50-60	2518	1795	3047	3600	Schneider
DA 8800	10	145	146,7	5179	DN150	F8500 MX+MY+MP	230/1/50-60	2518	1795	3341	3850	Schneider
DA 10800	10	145	180,0	6357	DN200	F11000 MX+MY+MP	230/1/50-60	2583	1875	3747	4200	Schneider

CORRECTION FACTORS FOR DA DRYERS

Bar	4.5	5	6	7	8	9	10
		0,69	0,75	0,88	1	1,12	1,25
Inlet Temp. °C	20	25	30	35	40	45	50
	1	1	1	1	0,80	0,73	0,59

DA Dryer Sizing Example;

If a compressor delivers 10 m³/min at 6 bar, the dryer inlet temperature is 40 °C. please choose your dryer as follows;

Dryer Capacity = 10 / 0,88 / 0,80 = 14,2 m³/min

The correct dryer model for this application is DA 850.

PRE FILTER (X)

Efficiency rating:
1 Micron particle removal & 0.5mg/m³ oil removal

FINE FILTER (Y)

Efficiency rating:
0.01 Micron particle removal & 0.01mg/m³ oil removal

PARTICLE FILTER (P)

Efficiency rating:
5 Micron particle removal
(removes desiccant particles after the dryer)

ACTIVATED CARBON FILTER (A)

Efficiency rating:
0.01 Micron particle removal & 0.003 mg/m³ oil removal



They use a blower to draw in the ambient air and pass it through a heater. The heated air is sent in the opposite direction to the drying flow. This removes the moisture from the chemical substance pores. The advanced control system continuously monitors dew point and adjusts the temperature. This results in energy savings. The heater is insulated for high energy efficiency.



Advantages

- Dew point monitoring and control
- Computer control
- Status, alarm, and pressure display
- Remote start and stop
- Low-pressure alarm
- High-pressure switches and alarms
- Externally heated or heat-free operation
- Reliable electronic control units
- User friendly and Different language options



MODEL	Max. Pressure		Capacity		Connection Size	Filter Set	Voltage	Dimensions (mm)			Controller
	bar	psi	m³/min	cfm				V/ph/Hz	Length	Width	
DBP 850	10	145	14,2	500	G 2"	GK0851 MX+MY+MP(H)	400 / 3 / 50	1296	1180	2299	Schneider
DBP 1000	10	145	16,7	589	G 2"	GK01210 MX+MY+MP(H)	400 / 3 / 50	1200	1310	2415	Schneider
DBP 1250	10	145	20,8	736	DN80	GK01820 MX+MY+MP(H)	400 / 3 / 50	1610	1270	2468	Schneider
DBP 1500	10	145	25,0	883	DN80	GK01820 MX+MY+MP(H)	400 / 3 / 50	1610	1270	2563	Schneider
DBP 1800	10	145	30,0	1059	DN80	GK01820 MX+MY+MP(H)	400 / 3 / 50	1563	1515	2479	Schneider
DBP 2200	10	145	36,7	1295	DN80	GK02220 MX+MY+MP(H)	400 / 3 / 50	1563	1455	2789	Schneider
DBP 2700	10	145	45,0	1589	DN80	GK02700 MX+MY+MP(H)	400 / 3 / 50	1615	1514	2836	Schneider
DBP 3200	10	145	53,3	1883	DN100	GK03200 MX+MY+MP(H)	400 / 3 / 50	1710	1660	3054	Schneider
DBP 3600	10	145	60,0	2119	DN100	GK04300 MX+MY+MP(H)	400 / 3 / 50	1710	1660	3268	Schneider
DBP 4400	10	145	73,3	2590	DN100	GK04300 MX+MY+MP(H)	400 / 3 / 50	1975	2492	2910	Schneider
DBP 5000	10	145	83,3	2943	DN 150	F6500 MX+MY+MP(H)	400 / 3 / 50	2045	2560	3382	Schneider
DBP 6300	10	145	105,0	3708	DN150	F6500 MX+MY+MP(H)	400 / 3 / 50	2090	2963	3328	Schneider
DBP 7200	10	145	120,0	4238	DN150	F8500 MX+MY+MP(H)	400 / 3 / 50	2020	3363	3047	Schneider
DBP 8800	10	145	146,7	5179	DN150	F8500 MX+MY+MP(H)	400 / 3 / 50	2020	3363	3341	Schneider
DBP 10800	10	145	180,0	6357	DN200	F11000 MX+MY+MP(H)	400 / 3 / 50	2492	3481	3765	Schneider
DBP 12000	10	145	200,0	7063	DN200	F11000 MX+MY+MP(H)	400 / 3 / 50	*	*	*	Schneider
DBP 16000	10	145	267,0	9429	DN200	F14000 MX+MY+MP(H)	400 / 3 / 50	*	*	*	Schneider

Dew point monitoring and control are standard.

* Please contact the sales consultant.

CORRECTION FACTORS FOR DBP AIR DRYERS							
Bar	4,5	5	6	7	8	9	10
	0,69	0,75	0,88	1	1,12	1,25	1,37
Inlet Temp. °C	20	25	30	35	40	45	-
	1	1	1	1	0,80	0,73	-

DBP Dryer Sizing Example;

If a compressor delivers 35 m³/min at 6 bar, the dryer inlet temperature is 40 °C. please choose your dryer as follows;

Dryer Capacity = 35 / 0,88 / 0,80 = 49,7 m³/min

The correct dryer model for this application is DBP 3200.

PRE FILTER (X)

Efficiency rating:
1 Micron particle removal & 0.5mg/m³ oil removal

FINE FILTER (Y)

Efficiency rating:
0.01 Micron particle removal & 0.01mg/m³ oil removal

PARTICLE FILTER (P)

Efficiency rating:
5 Micron particle removal
(removes desiccant particles after the dryer)

ACTIVATED CARBON FILTER (A)

Efficiency rating:
0.01 Micron particle removal & 0.003mg/m³ oil removal



High-quality compressed air is crucial to many industries and plays a particularly vital role in breathing air applications. Dalgakiran breathing air purifiers are designed to destroy harmful substances in the air in accordance with applicable standards.

Contaminants	CSA Z180.1	European Pharmacopoeia	OHS A Grade D
Water	Pressure dew point of 5°C below lowest system temp.	67 ppm [-45°C atmospheric dew point]	-
Oil/Lubricant	<1 mg/m ³	0,1 mg/m ³	5 mg/m ³
Carbon Dioxide (CO ₂)	<500 ppm	<500 ppm	<1000 ppm
Carbon Monoxide (CO)	<5 ppm	<5 ppm	<10 ppm
Nitrogen Oxides (NO+NO ₂)	-	<2 ppm	-
Sulphur Dioxide (SO ₂)	-	<1 ppm	-
Oxygen (O ₂)	-	21±1	-
Taste and Odor	-	Free	-

Model	Capacity		Max. Pressure (bar)	Connection Size	Replacement Filter Kit Model	Voltage	
	(m ³ /min)	(cfm)					
DBS 5	0,17	5	16	G 1/2"	G100-ELM	230/1/50-60	MODULAR
DBS 10	0,33	10	16	G 1/2"	G100-ELM	230/1/50-60	
DBS 15	0,42	15	16	G 1/2"	G100-ELM	230/1/50-60	
DBS 20	0,58	20	16	G 1/2"	G100-ELM	230/1/50-60	
DBS 25	0,75	25	16	G 1/2"	G150-ELM	230/1/50-60	
DBS 30	0,83	30	16	G 1/2"	G200-ELM	230/1/50-60	
DBS 40	1,17	40	16	G 1 1/2"	G250-ELM	230/1/50-60	
DBS 50	1,42	50	16	G 1 1/2"	G300-ELM	230/1/50-60	
DBS 60	1,67	60	16	G 1 1/2"	G500-ELM	230/1/50-60	
DBS 75	2,17	75	16	G 1 1/2"	G600-ELM	230/1/50-60	
DBS 100	2,83	100	16	G 1 1/2"	G851-ELM	230/1/50-60	
DBS 120	3,33	120	16	G 1 1/2"	G1210-ELM	230/1/50-60	
DBS 180	5,00	180	16	G 1 1/2"	ELM 300	230/1/50-60	
DBS 240	6,67	240	16	G 1 1/2"	ELM 300	230/1/50-60	
DBS 250	7,33	250	16	G 1 1/2"	ELM 300	230/1/50-60	TWIN TOWER
DBS 300	9,60	300	16	G 1 1/2"	ELM 600	230/1/50-60	
DBS 400	11,3	400	16	G 2"	ELM 600	230/1/50-60	
DBS 500	14,2	500	16	G 2"	ELM 600	230/1/50-60	
DBS 600	16,7	600	16	G 2"	ELM 600	230/1/50-60	
DBS 700	20,8	700	16	DN80	ELM 800	230/1/50-60	
DBS 800	25,0	800	16	DN80	ELM 1200	230/1/50-60	
DBS 1000	28,3	1000	16	DN80	ELM 1200	230/1/50-60	
DBS 1250	36,7	1250	16	DN80	ELM 1600	230/1/50-60	

FILTRATION, SEPARATION AND AIR RECEIVER

GO - Compressed Airline Filters.....	28
GON - Compressed Airline Filters.....	30
HGO - High Pressure Airline Filters	32
G MSS - Medical Sterile Filters.....	33
F - Flanged Compressed Air Filters.....	34
G WS - Water Separators.....	36
F WS - Flanged Water Separators.....	37
ELM-C - Carbolescer.....	38
DACT - Activated Carbon Towers.....	40
DHT - Air Receiver.....	41

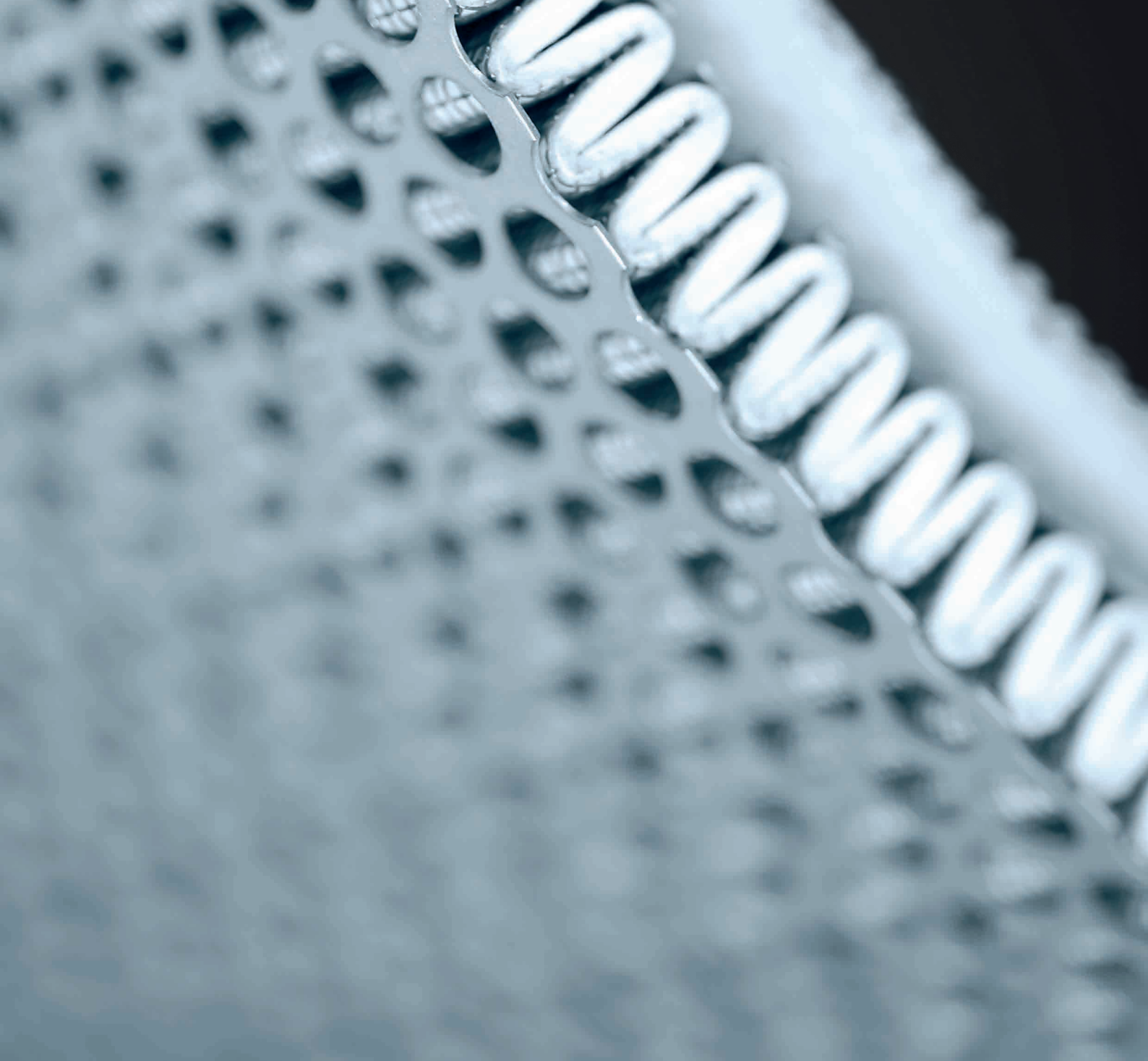



They efficiently prevent oil and dust particles which could come from the lubrication of the compressor element, the intake air, and the compressor installation itself. Hertz's engineering and design approach of air quality and energy efficiency has offered to products that provide highest air quality, lowest power consumption and lowest total cost of ownership.

Advantages

- More convenient for the end user
- Robust and durable
- High efficiency
- Low pressure drop
- Easy to maintain
- High-protected filter
- Electronic, external, loss-free, and manual drain options
- Durable element structure
- High-efficiency drainage layer



TO REMOVE THE ELEMENT
TWIST CLOCKWISE



MODEL	Max. Pressure		Capacity		Connection Size	Element Model	Dimensions (mm)			
	bar	psi	m ³ /min	cfm			A	B	C	D
GO 25	20	290	0,42	15	G 1/2"	M025	102	214,5	192,5	45
GO 50	20	290	0,83	29	G 1/2"	M050	102	214,5	192,5	45
GO 100	20	290	1,67	59	G 1/2"	M0100	102	252,5	230,5	45
GO 150	20	290	2,50	88	G 1"	M0150	123	297,5	270,5	45
GO 200	20	290	3,33	118	G 1"	M0200	123	361,5	334,5	45
GO 250	20	290	4,17	147	G 1"	M0250	123	401,5	374,5	45
GO 300	20	290	5,00	177	G 1 1/2"	M0300	123	458	422,5	45
GO 500	20	290	8,33	294	G 1 1/2"	M0500	123	488	452,5	45
GO 600	20	290	10,0	353	G 1 1/2"	M0600	123	533	497,5	45
GO 851	20	290	14,2	501	G 2"	M0851	160	622,5	581	45
GO 1210	20	290	20,2	712	G 2"	M01210	160	692,5	651	45
GO 1520	20	290	25,3	895	G 3"	M01520	194	725,5	669	45
GO 1820	20	290	30,3	1071	G 3"	M01820	194	865	808	45
GO 2220	20	290	37,0	1307	G 3"	M02220	194	919,5	863	45
GO 2700	20	290	45,0	1589	G 3"	M02700	194	1063,5	1007	45

CORRECTION FACTORS FOR GO COMPRESSED AIR FILTER SERIES										
Operating Pressure (bar)	1	3	5	7	9	11	13	15	16	20
PSIG	15	44	73	100	131	160	189	218	232	290
Correction Factor	0,5	0,71	0,87	1	1,12	1,22	1,32	1,44	1,50	1,63

HGO Compressed Air Filter Sizing Example;

If a compressor delivers 24 m³/min at 11 psi please choose your Filter model as follow: 24 m³/min / 1,22=19,7m³/min your model is HGO 1210.

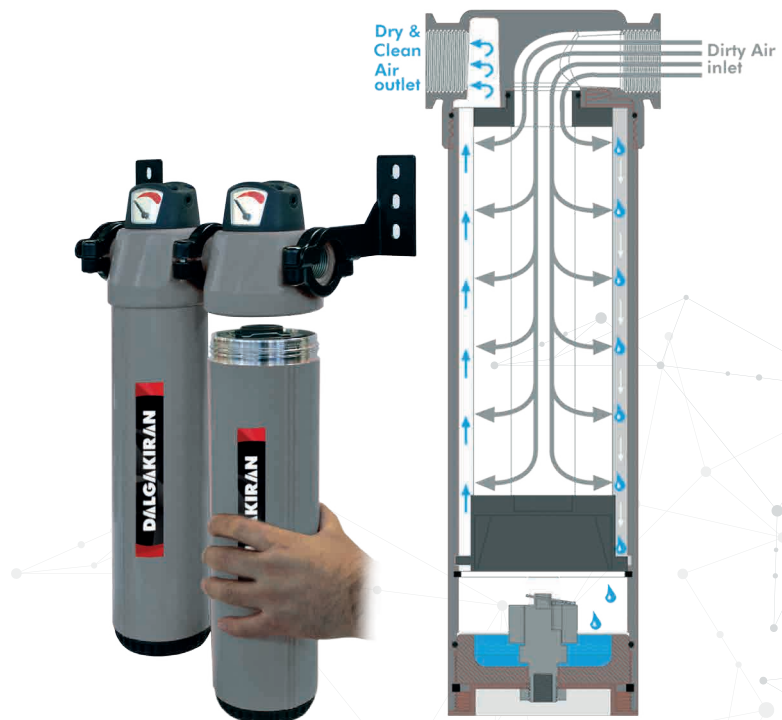



Dalgakiran's GON Series of Industrial Air Filters offer its compressed air users high-efficiency filtration with low pressure losses. Having more port sizes, it delivers a reliable performance, minimising air contamination in compressed air systems. The innovative "Zero Clearance" design allows users to assemble and replace the filter and other components in any compressed air unit easily. Constructed of aluminium, the GON series is built to last, meets PED and ISO 8573 standards, and is extremely economical.



Advantages

- Air flow from 35 m³/h to 5400 m³/h
- NPT/BSP pipe sizes range from ¼" to 4" inclusive
- Pore-free aluminium construction
- Options:
 - "Standard Drain" with a ½" connector or
 - "Drain-free" with a ½" connector and adaptor.
- Neatly designed connection clips and wall apparatus
- ISO 8573-compliant production
- Zero clearance
- Anodised
- Locking System Indicator



MODEL	Connection Size			Flow Rate		Max. Working Pressure (bar)	Element Model	Housing Dimensions (mm)				
				(m ³ /min)	cfm			A	B	C	D	E
GON-35	1/4"	3/8"	1/2"	0,58	20	20	MON35	90	36,5	214	192	19
GON-55	1/4"	3/8"	1/2"	0,91	32	20	MON55	90	36,5	251,5	230	19
GON-70	3/8"	1/2"	-	1,16	41	20	MON70	128	45	273	249,5	32
GON-100	3/8"	1/2"	-	1,66	59	20	MON100	128	45	302,5	279	32
GON-125	3/8"	1/2"	-	2,08	73	20	MON125	128	45	343	319,5	32
GON-150	3/4"	1"	-	2,50	88	20	MON150	140	45	369	334,5	31
GON-225	3/4"	1"	-	3,75	132	20	MON225	140	45	398	364,5	31
GON-300	1 1/4"	1 1/2"	-	5	177	20	MON300	140	45	474	432	31
GON-400	1 1/4"	1 1/2"	-	6,66	235	20	MON400	140	45	564	522	31
GON-500	1 1/4"	1 1/2"	2"	8,33	295	20	MON500	151	45	511	464,5	25
GON-600	1 1/2"	1 1/2"	2"	10	353	20	MON600	151	45	626	579,5	25
GON-800	1 1/4"	1 1/2"	2"	13,33	471	20	MON800	151	45	696	649,5	25
GON-1000	1 1/4"	1 1/2"	2"	16,66	588	20	MON1000	151	45	851	804,5	25
GON-1200	1 1/4"	1 1/2"	2"	20	706	20	MON1200	151	45	976	929,5	25
GON-1550	2 1/2"	3"	-	25,83	912	20	MONHC1550	240	45	707	659,5	25
GON-2000	2 1/2"	3"	-	33,33	1177	20	MONHC2000	240	45	862	814,5	25
GON-2700	2 1/2"	3"	-	45	1589	20	MONHC2700	240	45	987	939,5	25

Head Clamping

Head clamping connects filters in series without the need for more pipes and uses connection clamps to join multiple filters together. Wall-mounting apparatus lets you fix the filters to the walls with ease.

Drainage Pipes

Drainage pipes support the flow of moisture.

Correction Factor

Multiply the model flow rate shown in the table below by the correction factor corresponding to the working pressure to calculate the maximum flow rate of the filter model.





This model filters are produced in a weldless structure to withstand high pressures. High-pressure test guarantee safe and efficient operation.



Advantages

- Durable and compact
- Safe and efficient operation
- High performance
- Strong and reliable design
- Excellent high-pressure applications
- Product performance warranty
- Carbon steel filters designed for 350 bar (optional)
- Sufficient wall thickness
- High-pressure tested
- Anodised interior and exterior surfaces

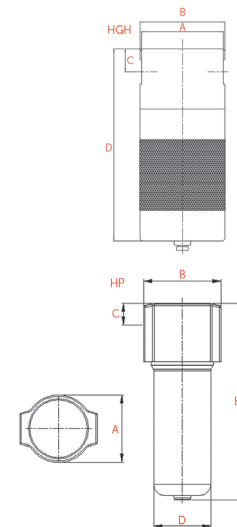

MODEL	Max. Pressure		Capacity		Connection Size	Element Model	Dimensions (mm)			
	bar	psi	m ³ /min	cfm			A	B	C	D
HGO 100	50	725	1,7	59	G 1/4"	M25	113,4	115,4	25,75	155
HGO 300	50	725	5,0	177	G 1/2"	M50	113,4	115,4	25,75	158,5
HGO 600	50	725	10,0	353	G 3/4"	M100	109,4	115,4	32,25	207
HGO 850	50	725	14,2	500	G 1"	M150	133	138	37,35	250
HGO 1200	50	725	20,0	706	G 1"	M200	133	138	37,35	314
HGO 1600	50	725	26,7	942	G 1 1/2"	M250	128	138	44,4	368
HGO 2500	50	725	41,7	1471	G 2"	M2500	145	158	51,5	393
HGO 3000	50	725	50,0	1766	G 2 1/2"	M3000	160	178	57,6	386

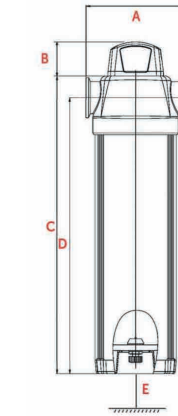

Advantages

- Specially designed for medical compressed air plants
- Partical removal down to 0.01 micron
- Suitable for steam sterilisation in an autoclave

MODEL	Max. Pressure		Capacity		Conne- ction Size	Dimensions (mm)				
	bar	psi	m ³ /min	cfm		A	B	C	D	E
G 20 MSS	16	232	0,33	12	G 1/4"	72	19	193	100	22
G 25 MSS	16	232	0,42	15	G 1/4"	72	19	193	100	22
G 40 MSS	16	232	0,67	24	G 3/8"	96	20	237	110	22
G 50 MSS	16	232	0,83	30	G 3/8"	96	20	237	110	22
G 100 MSS	16	232	1,67	59	G 1/2"	96	20	237	150	22
G 150 MSS	16	232	2,50	88	G 3/4"	117	34	375	190	56
G 200 MSS	16	232	3,33	118	G 3/4"	117	34	375	250	56
G 250 MSS	16	232	4,17	147	G 1"	117	34	465	300	56
G 300 MSS	16	232	5,00	177	G 1 1/4"	117	34	465	350	56
G 500 MSS	16	232	8,33	294	G 1 1/4"	117	34	530	380	56
G 600 MSS	16	232	10,0	353	G 1 1/2"	117	34	530	425	56
G 851 MSS	16	232	14,2	501	G 2"	170	64	722	480	56
G 1210 MSS	16	232	20,2	712	G 2"	170	64	722	550	56
G 1520 MSS	16	232	25,3	895	G 2 1/2"	235	72	760	430	56
G 1820 MSS	16	232	30,3	1071	G 3"	235	72	760	550	56
G 2220 MSS	16	232	37,0	1307	G 3"	235	72	760	600	56



They filter unwanted substances in the compressed air before they go to the system.



Advantages

- Simple design to replacement to internal element
- Two external float drains for excellent drainage
- CE and ASME tank options
- Low pressure drop
- Durable epoxy powder coating and rust-preventing anodised interior surface coating
- Strong welds
- Long service life



Model	Capacity		Connection Size	Drain Port Size	Maximum working Pressure bar	Element Model	Number of Elements	Housing Dimensions (mm)				
	m ³ /min	cfm						A	B	C	D	E
F 2400	40,0	1413	DN80	G 1/2"	14	M1200	2	450	1287	277	747	650
F 3600	60,0	2119	DN100	G 1/2"	14	M1200	3	450	1317	277	767	650
F 4800	80,0	2825	DN100	G 1/2"	14	M1200	4	530	1344	279	769	650
F 7200	120,0	4238	DN150	G 1/2"	14	M1200	6	580	1425	331	769	650
F 9600	160,0	5650	DN150	G 1/2"	14	M1200	8	650	1439	333	798	650
F 12000	200,0	7063	DN200	G 1/2"	14	M1200	10	750	1504	345	825	650
F 16800	280,0	9888	DN200	G 1/2"	14	M1200	14	800	1545	383	833	650
F 19200	320,0	11301	DN250	G 1/2"	14	M1200	16	850	1583	417	862	650
F 20400	340,0	12007	DN300	G 1/2"	14	M1200	17	850	1680	447	887	650
F 27600	460,0	16245	DN350	G 1/2"	14	M1200	23	850	1778	487	917	650
F 33600	560,0	19776	DN350	G 1/2"	14	M1200	28	850	1778	487	917	650

Specifications	Pre Filtering	General Purpose	Oil Removal	Activated Carbon
Grade	P	X	Y	A
Particle Removal (Micron)	5	1	0,01	0,01
Max. Oil carryover at 21°C (mg/m ³)	5	0,5	0,01	0,003
Max. working Temperature (°C)	80	80	80	25
Max. working Pressure	16	16	16	16
Initial Pressure loss (mbar)	40	80	100	80
Pressure loss for element change (mbar)	700	700	700	700
Element colour code	WHITE	WHITE	WHITE	METAL SS

CORRECTION FACTORS FOR F COMPRESSED AIR FILTER

Operating Pressure (barg)	1	3	5	7	9	11	13	15	16
PSIG	15	44	73	100	131	160	189	218	247
Correction Factor	0,5	0,71	0,87	1	1,12	1,22	1,32	1,44	1,57

F Compressed Air Filter Sizing Example;

If a compressor delivers 140 m³/min at 11 bar please choose your Filter model as follow:

140 m³/min / 1,22=114,8 m³/min your model is F 7200.

NOTES

- Grade A must not operate in oil saturated conditions.
- Grade A elements should be replaced periodically to suit the applications but must be changed at least every six months.
- Grade A will not remove certain gases including carbon monoxide and carbon dioxide. Please refer to works if in doubt.
- Flow rates are based on a 7 bar operating Pressure, for flows at other. Pressures use correction factor given above.
- All filters are suitable for use with mineral and synthetic oils.
- Other standards for flanged connections are available.
- Direction of air flow, inside to out, through filter element

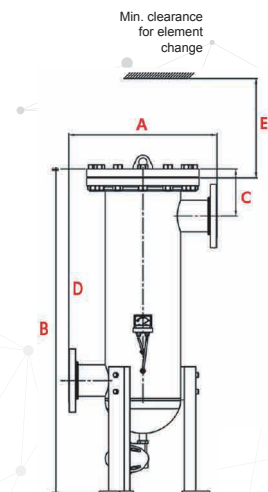



Dalgakiran water separators are designed to remove liquid water and some particulates in compressed air at the compressor outlet. Their unique centrifugal effect separates heavier-than-air matter and the low pressure drop makes them energy-efficient.



Advantages

Dalgakiran's G WS water separators have 1/4" - 3" pipes for flow rates of 2200 m³/h. Line filters should be used to remove unwanted substances left in the compressed air after the extremely efficient water separators.

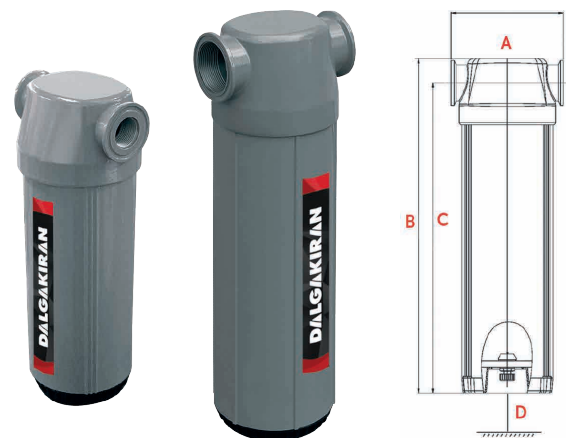

MODEL	Max. Pressure		Capacity		Connection Size	Dimensions (mm)			
	bar	psi	m ³ /min	cfm		A	B	C	D
G 25 WS	16	232	0,4	15	G 1/4"	103	257,5	236	160
G 100 WS	16	232	1,7	59	G 1/2"	103	257,5	236	210
G 200 WS	16	232	3,3	118	G 3/4"	123	304	277	285
G 300 WS	16	232	5,0	177	G 1"	123	304	277	380
G 600 WS	16	232	10,0	353	G1 1/2"	123	320	285	470
G 1200 WS	16	232	20,0	706	G 2"	160	484	443	560
G 2200 WS	16	232	36,7	1295	G 3"	193	546	490	610

CORRECTION FACTORS FOR HG WS COMPRESSED AIR FILTER SERIES

Operating Pressure (barg)	1	3	5	7	9	11	13	15	16	20
PSIG	15	44	73	100	131	160	189	218	232	290
Correction Factor	0,5	0,71	0,87	1	1,12	1,22	1,32	1,44	1,57	1,63



Dalgakiran water separators are designed to remove liquid water and some particulates in compressed air at the compressor outlet. Their unique centrifugal effect separates heavier-than-air matter and the low pressure drop makes them energy-efficient.



Advantages

F WS models have 3" - 8" pipes for flow rates up to 14.000 m³/h. Line filters should be used to remove unwanted substances left in the compressed air after the extremely efficient water separators.

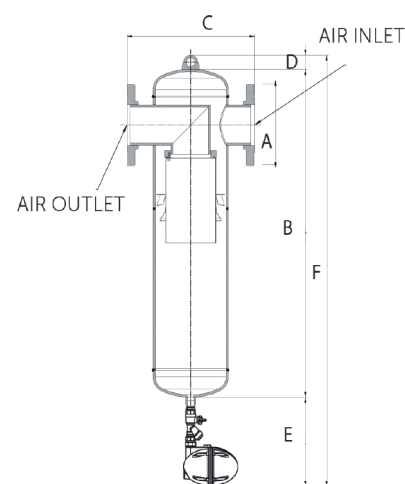

MODEL	Max. Pressure		Capacity		Conne- tion Size	Dimensions (mm)					
	bar	psi	m ³ /min	cfm		A	B	C	D	E	F
F 2500 WS	14	203	41,6	1471	DN80	200	934	450	75	280	1289
F 3200 WS	14	203	53,3	1883	DN100	220	964	450	75	280	1319
F 4300 WS	14	203	71,6	2531	DN100	220	928	530	75	280	1283
F 6500 WS	14	203	108,3	3826	DN150	285	1092	580	75	280	1447
F 8500 WS	14	203	141,6	5003	DN150	285	1091	650	75	280	1446
F 11000 WS	14	203	183,3	6474	DN200	340	1168	750	75	280	1523
F 14000 WS	14	203	233,3	8240	DN200	340	1201	800	75	280	1556



Oil in aerosol form and oil mist lower the quality of the compressed air and can damage pneumatic equipment. The patented Carbolescer can eliminate both the aerosol and mist forms of oil. It consists of a pleated separator layer, a carbon layer, and a particulate layer. The pleated separator layer removes the aerosol form of oil. When oily compressed air enters the unit, the oil droplets coalesce and run down the filter medium. The collected liquid oil is automatically drained off. The pleated separator filters out oil contaminants as small as 0.01 microns. In addition to the pleated separator, the activated carbon layer adsorbs oil mist. The oil mist is physically retained by the activated carbon granules and as a result, the oil content can be reduced to 0.003 ppm. The final particulate filter layer actively removes carbon dust and maintains the quality of the compressed air.

 **Advantages**

- Very low pressure drops
- Remaining oil aerosol content no more than 0.003 ppm
- Equal air distribution
- Long service life
- User-friendly replacement procedure
- Oil indicator

MAX. OPERATING PRESSURE (16 BAR)								
OPERATING PRESSURE (BAR)	1	3	5	7	9	11	13	14
CORRECTION FACTOR	0,5	0,71	0,87	1	1,12	1,22	1,32	1,38

MAX. OPERATING PRESSURE (40 BAR)														
OPERATING PRESSURE (BAR)	4,5	5	6	7	8	9	10	11	12	13	14	15	16	40
CORRECTION FACTOR	0,69	0,75	0,88	1	1,12	1,25	1,37	1,5	1,62	1,74	1,87	1,99	2,11	4

MODEL	Max. Remaining Oil Aerosol Content @ 21°C	Recommended Capacity @ 7 barg	Max. Operating Pressure	Connection Size Inlet-Outlet	Length	Height
	ppm	(Nm ³ /min)	(barg)		(mm)	(mm)
ELM-C G100-16	0,003	0,58	16	G 1/2"	102	302
ELM-C G150-16	0,003	0,75	16	G 1/2"	123	352
ELM-C G200-16	0,003	0,83	16	G 1"	123	412
ELM-C G250-16	0,003	1,16	16	G 1"	123	454
ELM-C G300-16	0,003	1,41	16	G 1 1/2"	123	507
ELM-C G500-16	0,003	1,66	16	G 1 1/2"	123	537
ELM-C G600-16	0,003	2,16	16	G 1 1/2"	123	583
ELM-C G850-16	0,003	2,83	16	G 1 1/2"	160	668
ELM-C G1210-16	0,003	3,33	16	G 2"	160	740
ELM-C F150-14	0,003	4,25	14	DN 50	500	1065
ELM-C F300-14	0,003	8,50	14	DN 50	500	1165
ELM-C F600-14	0,003	17	14	DN 50	500	1523
ELM-C F800-14	0,003	22,66	14	DN 80	500	1743
ELM-C F1200-14	0,003	34	14	DN 80	600	1606
ELM-C F1600-14	0,003	45,33	14	DN 80	600	1747
ELM-C F2100-14	0,003	59,50	14	DN 100	700	1651
ELM-C F2750-14	0,003	77,91	14	DN 100	700	1798
ELM-C F4200-14	0,003	119	14	DN 150	800	1750
ELM-C F6000-14	0,003	170	14	DN 150	800	1997
ELM-C F8000-14	0,003	226,66	14	DN 200	850	2095
ELM-C F10000-14	0,003	283,33	14	DN 250	1000	2208
ELM-C F12000-14	0,003	340	14	DN 300	1000	2775

MODEL	Max. Remaining Oil Aerosol Content @ 21°C	Recommended Capacity @ 7 barg	Max. Operating Pressure	Connection Size Inlet-Outlet	Length	Height
	ppm	(Nm ³ /min)	(barg)		(mm)	(mm)
ELM-C G15-50	0,003	1,41	50	*	*	*
ELM-C G25-50	0,003	2,83	50	*	*	*
ELM-C G50-50	0,003	5,66	50	*	*	*
ELM-C G75-50	0,003	8,50	50	*	*	*
ELM-C G100-50	0,003	11,33	50	*	*	*
ELM-C G125-50	0,003	14,16	50	*	*	*
ELM-C F150-40	0,003	17	40	DN 50	500	1065
ELM-C F300-40	0,003	34	40	DN 50	500	1165
ELM-C F600-40	0,003	68	40	DN 50	500	1523
ELM-C F800-40	0,003	90,66	40	DN 80	500	1743
ELM-C F1200-40	0,003	136	40	DN 80	600	1606
ELM-C F1600-40	0,003	181,33	40	DN 80	600	1747
ELM-C F2100-40	0,003	238	40	DN 100	700	1651
ELM-C F2750-40	0,003	311,66	40	DN 100	700	1798
ELM-C F4200-40	0,003	476	40	DN 150	800	1750
ELM-C F6000-40	0,003	680	40	DN 150	800	1997
ELM-C F8000-40	0,003	906,66	40	DN 200	850	2095
ELM-C F10000-40	0,003	1133,33	40	DN 250	1000	2208
ELM-C F12000-40	0,003	1360	40	DN 300	1000	2775

* Please contact your sales representative



Some industries require the compressed air to be clean of oil mist and the smell of oil. The DACT series of activated carbon towers remove the oil mist and the smell from the compressed air.



Advantages

- Reduces the oil content in the compressed air to 0.003 mg/m³
- Provides high-quality air
- Serves such sectors as hospital, pharma, food-drink, etc.

CORRECTION FACTORS

Operating Pressure (bar)	1	3	5	7	9	10
PSIG	15	44	73	100	131	145
Correction Factor	0,5	0,71	0,87	1	1,12	1,15

MODEL	Max. Pressure		Capacity		Connection Size	Dimensions (mm)		
	bar	psi	m ³ /min	cfm		Length	Width	Height
DACT 130	10	145	2,17	77	G 1"	347	450	1172
DACT 185	10	145	3,08	109	G 1"	450	563	1413
DACT 250	10	145	4,17	147	G 1"	430	601	1370
DACT 300	10	145	5,00	177	G 1 1/2"	500	649	1336
DACT 360	10	145	6,00	212	G 1 1/2"	500	649	1336
DACT 440	10	145	7,33	259	G 1 1/2"	500	648	1536
DACT 575	10	145	9,58	338	G 2"	469	604	1733
DACT 680	10	145	11,3	400	G 2"	550	540	1936
DACT 850	10	145	14,2	500	G 2"	580	600	1957
DACT 1000	10	145	16,7	589	DN80	657	638	1617
DACT 1250	10	145	20,8	736	DN80	708	880	2400
DACT 1500	10	145	25,0	883	DN80	708	880	2558
DACT 1800	10	145	30,0	1059	DN80	810	980	2423
DACT 2200	10	145	36,7	1295	DN80	810	1100	2600
DACT 2700	10	145	45,0	1589	DN100	910	1100	2758
DACT 3200	10	145	53,3	1883	DN100	866	1050	3023
DACT 3600	10	145	60,0	2119	DN100	866	1050	3237
DACT 4400	10	145	73,3	2589	DN150	1130	1250	2914
DACT 5000	10	145	83,3	2943	DN150	1130	1310	3420
DACT 6300	10	145	105,0	3708	DN150	1230	1410	3365
DACT 7200	10	145	120,0	4237	DN 150	1430	1575	3075
DACT 8800	10	145	146,7	5179	DN150	1430	1575	3369
DACT 10800	10	145	180,0	6356	DN200	1430	1650	3863



Air tanks are used for storage in compressed air systems. They prevent pressure fluctuations in the system and eliminate inefficiencies especially in fix speed compressor applications.

Advantages

- They allow the system to respond quickly to high and sudden consumption
- A key component of compressed air systems
- Storage function
- Reduces system pressure fluctuations
- Increases efficiency
- Galvanized and stainless steel options
- Energy saving
- Highly durable with a long service life

Model	Volume L	Pressure bar	Configura- tion	Dimensions (mm)		Connection Inlet / Outlet
				Diameter	Height	
DHT 100	100	10	VERTICAL	324	1564	G 1"
		15	VERTICAL	324	1564	G 1"
DHT 200	200	10	VERTICAL	450	1618	G 1"
		15	VERTICAL	450	1618	G 1"
DHT 300	300	10	VERTICAL	450	1918	G ¾"
		15	VERTICAL	450	1918	G ¾"
		40	VERTICAL	450	2012	G 1"
DHT 500	500	10	VERTICAL	642	1980	G 1"
		15	VERTICAL	642	1970	G 1"
		40	VERTICAL	642	2083	G 1 ½"
DHT 900	900	10	VERTICAL	800	2120	G 1 ½"
		10	VERTICAL	850	2120	G 1 ½"
DHT 1000	1000	15	VERTICAL	850	2120	G 1 ½"
		40	VERTICAL	850	2120	G 1 ½"
		10	VERTICAL	1150	2150	G 2"
DHT 1800	1800	15	VERTICAL	1150	2150	G 2"
		10	VERTICAL	1080	2566	G 2"
DHT 2000	2000	15	VERTICAL	1080	2566	G 2"
		15	VERTICAL	1150	2240	G 2"
		10	VERTICAL	1400	2370	G 2 ½"
DHT 3000	3000	15	VERTICAL	1400	2370	G 2 ½"
		10	VERTICAL	1400	3120	G 3"
DHT 4000	4000	15	VERTICAL	1400	3120	G 3"
		10	VERTICAL	1400	3870	G 3"
DHT 5000	5000	15	VERTICAL	1400	3870	G 3"
		10	VERTICAL	1500	3930	G 3"
DHT 6000	6000	15	VERTICAL	1500	3930	G 3"
		10	VERTICAL	1750	4040	DN100
DHT 8000	8000	15	VERTICAL	1750	4040	DN100
		10	VERTICAL	1900	4100	DN100
DHT 10000	10000	15	VERTICAL	1900	4100	DN100

NITROGEN AND OXYGEN GENERATORS

DGN - Nitrogen Generators	44
DDX - Nitrogen Purifier Systems	46
DCX - Nitrogen Purifier	48
DO2 - Oxygen Generators	50

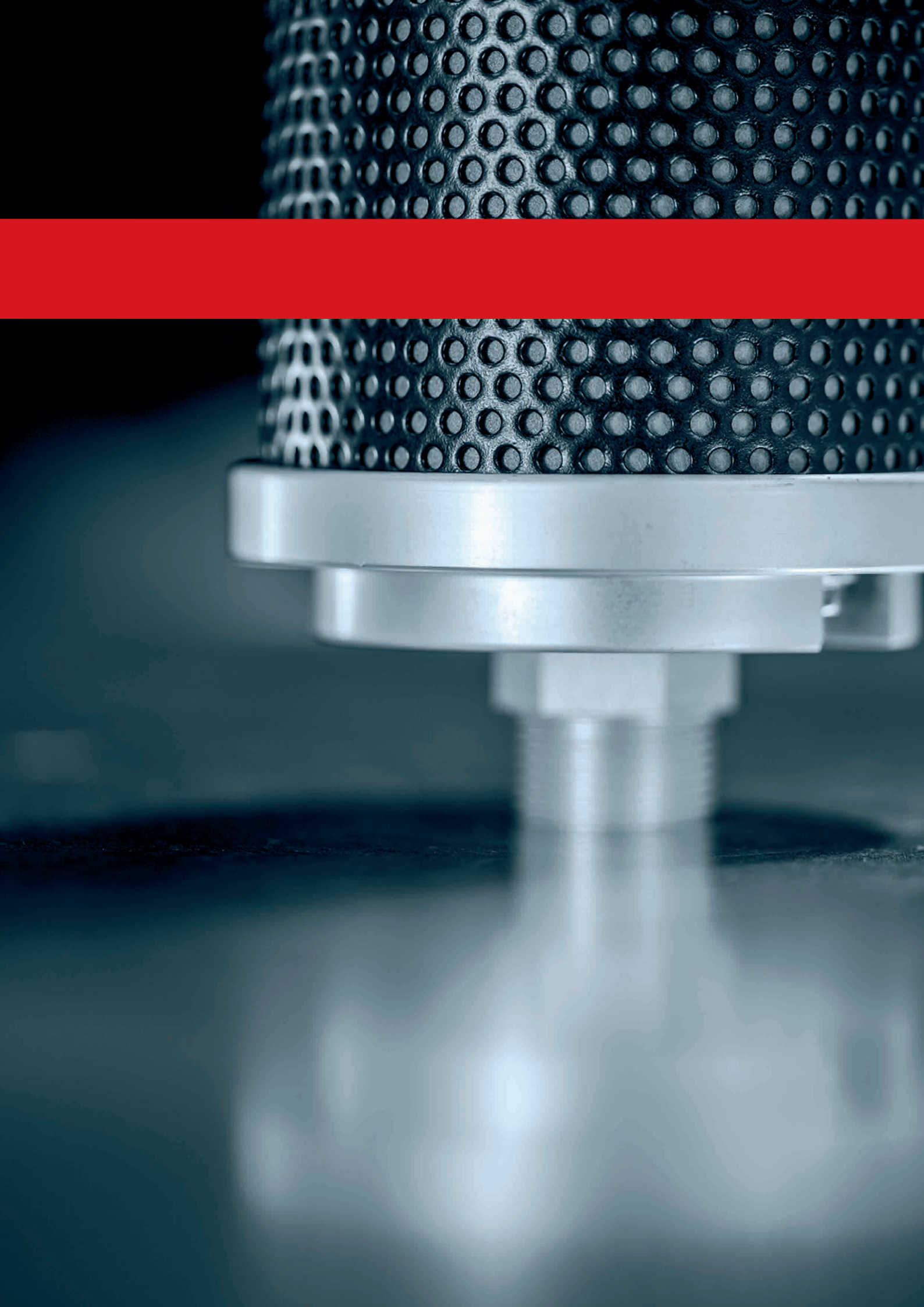



Thanks to the PSA technology utilized by Dalgakiran nitrogen generators, you can produce nitrogen gas with up to 99.999% purity within the capacity range of 0.5-5000 Nm³/h.

These generators produce nitrogen from the compressed air available. The compressed air is cleaned by pre-filtration which eliminates impurities, such as humidity, oil vapours, particles and hydrocarbons.

The filtered compressed air is directed to two CMS filled columns. While the compressed air is passing through the generator, the oxygen and carbon dioxide molecules are removed and the pressure dew point is lowered. The generated nitrogen gas is clean, dry and of high purity so that it can be used for a wide variety of applications.

The parameters such as compressed air temperature, pressure, nitrogen purity and nitrogen pressure are all monitored continuously. Dalgakiran nitrogen generators guarantee sustainable and high efficiency production.



Advantages

- Stainless steel pipes and process valves
- Zirconia oxygen sensor
- Outlet pressure sensor
- Visual & Audio alarm for low purity
- Visual & Audio alarm for low pressure
- Visual alarm for periodical maintenance
- Automatic start/stop
- Outlet nitrogen regulator
- Outlet nitrogen needle valve
- Advanced energy saving kit
- Siemens S/ 1200 PLC

Model	Free Nitrogen Delivery @ Following Purity Level (Nm ³ /min)								
	95,00%	97,00%	98,00%	99,00%	99,50%	99,90%	99,99%	99,995%	99,999%
DGN 25	0,097	0,082	0,070	0,053	0,042	0,027	0,017	0,012	0,008
DGN 50	0,182	0,148	0,133	0,100	0,083	0,053	0,025	0,020	0,017
DGN 80	0,283	0,225	0,202	0,153	0,133	0,082	0,042	0,030	0,023
DGN 100	0,350	0,292	0,267	0,215	0,167	0,108	0,055	0,042	0,032
DGN 150	0,525	0,433	0,400	0,317	0,250	0,158	0,083	0,062	0,042
DGN 250	0,833	0,675	0,597	0,475	0,417	0,217	0,108	0,083	0,058
DGN 400	1,417	1,000	0,917	0,800	0,667	0,417	0,217	0,158	0,100
DGN 500	1,800	1,417	1,300	1,083	0,833	0,630	0,395	0,282	0,178
DGN 700	2,417	2,000	1,667	1,333	1,167	0,805	0,467	0,352	0,238
DGN 1000	3,583	2,917	2,467	1,917	1,667	1,200	0,700	0,527	0,357
DGN 1200	4,333	3,583	3,167	2,417	2,000	1,450	0,850	0,650	0,450
DGN 1700	6,250	5,167	4,500	3,467	2,833	2,167	1,250	0,933	0,642
DGN 2000	7,417	6,167	5,333	4,033	3,333	2,533	1,483	1,117	0,750
DGN 3000	10,583	8,750	7,667	6,000	5,000	3,617	2,100	1,583	1,083
DGN 4000	15,333	12,667	11,000	8,333	6,667	5,217	3,033	2,292	1,563
DGN 5500	19,167	15,833	13,833	10,583	9,167	6,533	3,783	2,867	1,942
DGN 6500	23,000	19,000	16,500	12,583	10,833	7,833	4,550	3,448	2,333
DGN 7500	26,667	22,083	19,333	14,667	12,500	9,417	5,417	4,083	2,783
DGN 8500	30,500	25,250	22,083	16,667	14,167	10,417	6,033	4,583	3,108
DGN 10000	38,333	31,667	27,500	21,000	16,667	12,333	7,583	5,733	3,867
DGN 12500	45,833	37,917	33,083	25,000	20,833	15,750	9,167	6,917	4,700

CMS Temperature (°C) - Correction Factor (Kt)									
Temperature °C	10	15	20	25	30	35	40	45	50
Correction Factor	1	1	1	1	0,94	0,86	0,81	0,77	0,72

Inlet Pressure (Barg) - Correction Factor (Kp)									
Pressure (bar[g])	6	6,5	7	7,5	8	8,5	9	9,5	10
Correction Factor	0,9	0,95	1	1,02	1,05	1,09	1,12	1,14	1,15

Purity (%) - Air / Nitrogen Ratio									
Purity (%)	95	97	98	99	99,5	99,9	99,99	99,995	99,999
Air/Nitrogen Ratio	1,9	2,1	2,3	2,6	2,9	3,28	4,61	5,11	6,59

Pressure Drop (Air Inlet - Generator Outlet)						
Purity (%)	95	97	98	99	99,5	99,9 - 99,999
Pressure (bar[g])	1,5	1,5	1,25	1,25	1	1



Dalgakiran's brand new DDX Nitrogen Treatment System offers an extremely economic means of increasing the required nitrogen purity beyond 99.9% to 99.999%.

The DDX Series uses a specially designed catalyst with a large surface area to increase nitrogen purity. The oxygen left on the catalyst surface after the reaction is reduced to no more than 10 ppm.

DDX Nitrogen Treatment Devices when used in conjunction with Nitrogen Generator System use small amounts of hydrogen to prevent compressed air loss and deliver very pure nitrogen. This system delivers very pure nitrogen while keeping power consumption to a minimum.



Advantages

- Short payback period
- Small footprint
- Long-lasting efficiency (> 10 years)
- Best quality high-performance solutions
- Investing in a lower capacity DDX system instead of a higher capacity DNG system for the same purity of nitrogen reduces costs and saves on energy
- Up to 99.999% nitrogen purity with minimum space and energy requirements
- Low energy consumption
- Low CO₂ emissions
- Heavy-duty build designed for hard conditions and industrial use
- High-quality and durable components
- System produces minimum 99.999% pure nitrogen with a very low air/nitrogen ratio (3.0 instead of 8.4).
- Compact design, fully automated system
- 24/7 nitrogen production at the desired purity
- High energy savings
- Low-cost and special production
- Minimum maintenance costs





Working Principle

Compared with existing applications, Dalgakıran's compact designed Nitrogen Treatment System can take nitrogen produced at 99.9% purity and convert it to 99.999% pure nitrogen while delivering considerable energy savings in nitrogen production costs.

The system uses a catalytic reaction to remove the oxygen left over from the DNG generator from the PSA Nitrogen Generator outlet by utilizing the reaction between the residual oxygen and hydrogen to produce 99.999% pure nitrogen. The only by-product of this catalytic reaction is water.

The low cost of the hydrogen needed for the reaction results in considerable long-term savings. In fact, this newly developed nitrogen purifier lets you produce extremely pure nitrogen using lower capacity air compressors and equipment.

As the reaction increases the temperature of the nitrogen, the DDX Nitrogen Purifying System is integrated into a High-Temperature Air Dryer, combining two products in a single unit for a complete solution.

Model	N ₂ 99.999% Purity (m ³ /min)
DDX 10	0,017
DDX 20	0,033
DDX 35	0,058
DDX 60	0,100
DDX 95	0,173
DDX 120	0,232
DDX 150	0,283
DDX 250	0,452
DDX 330	0,597
DDX 450	0,807
DDX 510	0,925
DDX 570	1,027
DDX 730	1,343
DDX 910	1,643
DDX 1110	1,998
DDX 1230	2,205
DDX 1370	2,443
DDX 1820	3,303
DDX 2050	3,852
DDX 2550	4,618
DDX 2950	5,697
DDX 3540	6,675
DDX 4160	7,698
DDX 5560	9,267
DDX 6050	11,438
DDX 7500	13,607
DDX 9170	15,283
DDX 11200	18,667

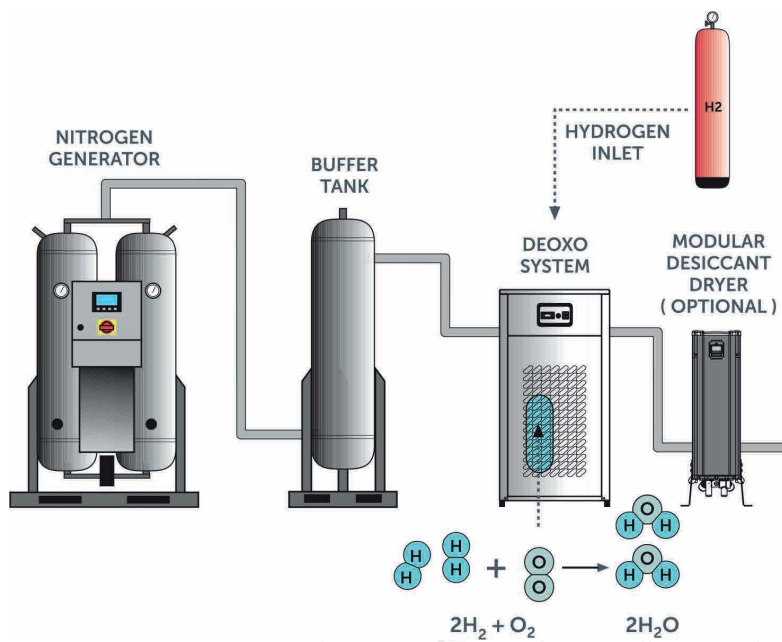
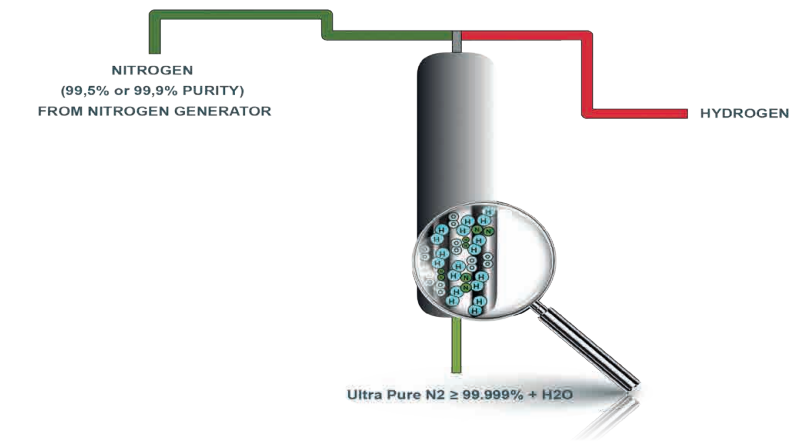



Most PSA Nitrogen Generator users require the highest levels of Nitrogen purity by the most cost-effective means possible.

Dalgakiran DCX Nitrogen Purifier System offers an extremely economic way to increase nitrogen purity levels beyond 99.9% all the way up to 99.9999% purity.

DCX is the true add-on technology for Nitrogen Generation applications requiring 1-5 ppm ultra high purity.

DCX can easily be integrated with already existing Nitrogen Generator System (free from brand) resulting in high purity nitrogen gas at minimum costs.



Advantages

- Easily integration with any brand of Nitrogen Generator
- Power Savings up to 50%
- Reduced compressed air consumption
- More effective pay-back time compared to the DCX-free system
- Class 6.0 quality highest purity nitrogen
- Auto purity control system
- Easy maintenance - compact design
- Minimized installation area
- Cost-effective through low operating costs

HOW IT WORKS?

The nitrogen gas obtained from a nitrogen generator is enriched with a minimum amount of hydrogen before it passes into the catalyst. The hydrogen reacts with the residual oxygen of the nitrogen, the chemical reaction being water vapor and heat, which are removed by filtration & drying.

Thanks to our innovative DCX system you can produce ultra-pure nitrogen with smaller air compressors.



Properties

- Fast start-up time
- Inlet and outlet N₂ purity control
- Inlet and outlet N₂ pressure sensors
- N₂ inlet flow (m³/h) and N₂ total volume (m³) monitoring
- N₂ outlet dew point (°C)
- H₂ Inlet flow (l/h) and H₂ total volume (liters)
- DCX reactor temperature sensor (°C)
- DCX reactor with auto-heater & insulation
- Working hours counter
- Remote control and monitoring
- Industry 4.0

Model	Nitrogen Purity (%)	Capacity (Nm ³ /min)	Power Consumption (kW/h)	Voltage	Noise Level dB(A)
DCX 20	99,9999	0,41	20	230/1/50	55-85
DCX 40	99,9999	0,66	28	230/1/50	55-85
DCX 60	99,9999	0,83	35	230/1/50	55-85
DCX 80	99,9999	1,33	51	230/1/50	55-85
DCX 100	99,9999	1,58	60	230/1/50	55-85
DCX 150	99,9999	2,33	90	230/1/50	55-85



Thanks to the PSA technology utilized by Dalgakiran Oxygen Generators, you can produce oxygen gas with up to 95 % purity within the capacity range of 0.5-2000 Nm³/h.

These generators produce oxygen from the compressed air available. The compressed air is cleaned by pre-filtration which eliminates impurities, such as humidity, oil vapours, particles and hydrocarbons.

The filtered compressed air is directed to two zeolite filled columns. While the compressed air is passing through the generator, the nitrogen and carbon dioxide molecules are removed and the pressure dew point is lowered. The generated oxygen gas is clean, dry and of high purity so that it can be used for a wide variety of applications.

The parameters such as compressed air temperature, pressure, oxygen purity and oxygen pressure are all monitored continuously. Dalgakiran oxygen generators guarantee sustainable and high efficiency production.

Pneumatic valves that ensure regular flow of air and oxygen during the process are manufactured from AISI 316L noncorrosive material. Owing to its long operation life, it provides problem free production for long years. Moreover, 316L stainless steel valves no need for maintenances.

Advantages

- Consistently high purity guaranteed
- Low compressed air consumption and maintenance costs
- Ease of use and maintenance
- Siemens S/1200 PLC
- Instant monitoring and recording of parameters such as purity, pressure, flow rate on the screen
- Visual and audio alarms for various parameters
- Remote control
- Fully automatic operation

Model	Free Oxygen Delivery @ Following Purity Level					
	90%		93%		95%	
	(m ³ /min)	cfm	(m ³ /min)	cfm	(m ³ /min)	cfm
D02 10	0,013	0,46	0,012	0,42	0,010	0,35
D02 20	0,023	0,81	0,020	0,71	0,017	0,60
D02 30	0,043	1,52	0,040	1,41	0,035	1,24
D02 40	0,063	2,22	0,058	2,05	0,053	1,87
D02 60	0,093	3,28	0,085	3,00	0,075	2,65
D02 100	0,163	5,76	0,142	5,01	0,133	4,70
D02 120	0,208	7,35	0,192	6,78	0,167	5,90
D02 150	0,250	8,83	0,225	7,95	0,205	7,24
D02 200	0,333	11,76	0,283	9,99	0,267	9,43
D02 300	0,500	17,66	0,448	15,82	0,417	14,73
D02 400	0,700	24,72	0,633	22,35	0,583	20,59
D02 600	1,000	35,31	0,917	32,38	0,833	29,42
D02 800	1,333	47,07	1,225	43,26	1,117	39,45
D02 1000	1,750	61,80	1,583	55,90	1,500	52,97
D02 1400	2,333	82,39	2,083	73,56	1,833	64,73
D02 1500	2,583	91,22	2,333	82,39	2,133	75,33
D02 2000	3,250	114,77	2,933	103,58	2,667	94,18
D02 2500	4,083	144,19	3,750	132,43	3,417	120,67
D02 3000	4,917	173,64	4,417	155,98	4,083	144,19
D02 4000	6,500	229,55	5,917	208,96	5,417	191,30

CMS CORRECTION FACTORS									
Temperature °C	10	15	20	25	30	35	40	45	50
Correction Factor	1	1	1	1	0,94	0,86	0,81	0,77	0,72

AIR INLET FACTORS				
Pressure (bar[g])	6	6,5	7	7,5
Correction Factor	0,9	0,95	1	1

AIR FACTORS			
Purity [%]	90	93	95
Air/Oxygen Ratio	11,5	12	12

PRESSURE DROP (AIR INLET - GENERATOR OUTLET)			
Purity [%]	90	93	95
Pressure (bar[g])	1,5	1,5	2

JOURNEY OF AIR

Headquarter

Eyup Sultan Mah. Muminler Cad. No: 70 34885 Sancaktepe / Istanbul / Türkiye

Factory

Makine Ihtisas OSB, Demirciler Mah. 1. Cad. No:1/2, Merkez, Dilovası / Kocaeli / Türkiye

Tel: +90 216 311 71 81 **e-mail:** info@dalgakiran.com

D/LG/KIRAN